

7SG11Argus

Overcurrent Protection Relays

Document Release History

This document is issue 2010/02 The list of revisions up to and including this issue is:

Pre release

| | |
|---------|--|
| 2010/02 | Document reformat due to rebrand |
| 2008/11 | Sixth issue: Instrumentation claims updated. |
| 2007/02 | Fifth issue: Thermal withstand and O/C operate claims updated to new std. |
| 2006/03 | Fourth issue: O/C Element reset levels updated |
| 2006/03 | Third issue: Editorial modifications, software revision histories updated. |
| 2004/05 | Second issue: Modification of CBF feature, DTL timers extended, CT Failure added, Auto Reclose sequence settings modified. Modbus protocol included and additional metering included. |
| 2002/12 | First issue |

Software Revision History

| | | |
|--|--|--|
| | | |
|--|--|--|

The copyright and other intellectual property rights in this document, and in any model or article produced from it (and including any registered or unregistered design rights) are the property of Siemens Protection Devices Limited. No part of this document shall be reproduced or modified or stored in another form, in any data retrieval system, without the permission of Siemens Protection Devices Limited, nor shall any model or article be reproduced from this document unless Siemens Protection Devices Limited consent.

While the information and guidance given in this document is believed to be correct, no liability shall be accepted for any loss or damage caused by any error or omission, whether such error or omission is the result of negligence or any other cause. Any and all such liability is disclaimed.

Contents

| | |
|---|-----------|
| Section 1: Performance Specification | 6 |
| 1.1 General..... | 6 |
| 1.1.1 CE Conformity..... | 6 |
| 1.1.2 Reference..... | 6 |
| 1.1.3 Dimensions and Weights..... | 6 |
| 1.2 Energising Quantities..... | 7 |
| 1.2.1 Characteristic Energising Quantities..... | 7 |
| 1.2.2 Auxiliary Energising Quantity..... | 8 |
| 1.3 Output Contacts..... | 9 |
| 1.4 Functional Performance..... | 9 |
| 1.4.1 Phase-fault Overcurrent Protection..... | 9 |
| 1.4.2 Earth-fault Overcurrent Protection..... | 11 |
| 1.4.3 Sensitive/Restricted Earth-fault Protection..... | 11 |
| 1.4.4 Directional Characteristics..... | 11 |
| 1.4.5 Circuit Breaker Fail..... | 12 |
| 1.4.6 Auto-reclose..... | 13 |
| 1.4.7 Instrumentation..... | 13 |
| 1.4.8 Communication Interface..... | 13 |
| 1.4.9 Real Time Clock..... | 13 |
| 1.5 Environmental Performance..... | 13 |
| 1.5.1 General..... | 13 |
| 1.5.2 Immunity..... | 14 |
| 1.5.3 Emissions..... | 15 |
| 1.5.4 Mechanical..... | 15 |
| Section 2: Functional Description | 20 |
| 2.1 Introduction..... | 20 |
| 2.1.1 Models..... | 21 |
| 2.1.2 Document Organisation..... | 21 |
| 2.2 Configuration..... | 22 |
| 2.2.1 Settings Groups..... | 22 |
| 2.2.2 System Frequency..... | 22 |
| 2.2.3 Current and Voltage Inputs..... | 23 |
| 2.2.4 Identifier..... | 24 |
| 2.2.5 General Alarms..... | 24 |
| 2.2.6 Direction Tags..... | 24 |
| 2.2.7 Real Time Clock..... | 25 |
| 2.2.8 Default Instruments..... | 25 |
| 2.2.9 Password..... | 25 |
| 2.3 Phase-fault and Earth-fault Overcurrent..... | 26 |
| 2.3.1 Delay Characteristic element..... | 26 |
| 2.3.2 Instantaneous elements..... | 27 |
| 2.3.3 Flashing (Pecking) Fault Protection..... | 29 |
| 2.4 Sensitive Earth-fault and Restricted Earth-fault..... | 30 |
| 2.4.1 High Impedance Restricted Earth-fault Scheme..... | 31 |
| 2.5 Primary Equipment Fail Protection..... | 31 |
| 2.5.1 Circuit Breaker (Trip) Fail Protection..... | 31 |
| 2.5.2 Close Fail..... | 32 |
| 2.5.3 Current Transformer Failure..... | 32 |
| 2.5.4 Trip Circuit Supervision - for details see sections 2.10 and 3.8..... | 33 |
| 2.6 Cold Load Protection..... | 33 |
| 2.7 Directional Control..... | 34 |
| 2.7.1 Polarisation..... | 34 |
| 2.7.2 Two-out-of-three Gate..... | 35 |
| 2.7.3 Voltage Memory..... | 35 |
| 2.8 Voltage Protection..... | 36 |
| 2.9 Auto-Reclose..... | 37 |
| 2.9.1 Auto Reclose Sequences..... | 38 |
| 2.9.2 Control Inputs..... | 43 |
| 2.9.3 Frequent Operations Counter..... | 44 |

| | | |
|--|--|-----------|
| 2.9.4 | Hot (Live) Line Working..... | 44 |
| 2.10 | Trip Circuit Supervision | 45 |
| 2.11 | Status inputs and Relay Outputs..... | 45 |
| 2.12 | Communications | 47 |
| 2.13 | Data Storage..... | 47 |
| 2.13.1 | Event Storage | 47 |
| 2.13.2 | Fault Data Record..... | 47 |
| 2.13.3 | Waveform (Disturbance) Records..... | 48 |
| 2.13.4 | Maximum Demand Function | 49 |
| 2.14 | Maintenance | 50 |
| 2.14.1 | Circuit Breaker Operations..... | 50 |
| 2.14.2 | Output Relay Test | 51 |
| 2.14.3 | Internal Supervision | 52 |
| 2.15 | Linesman Mode | 52 |
| Section 3: Application Notes | | 54 |
| 3.1 | Selection of Characteristics..... | 54 |
| 3.1.1 | Reset Delay | 54 |
| 3.2 | Directional Protection | 54 |
| 3.2.1 | Parallel or Ring Feeder Protection | 54 |
| 3.3 | Sensitive Earth-fault Protection | 55 |
| 3.4 | Blocking Schemes..... | 56 |
| | Busbar Zone Protection | 57 |
| 3.5 | High Impedance Restricted Earth-fault Protection | 58 |
| 3.6 | Circuit Breaker Fail Protection | 60 |
| 3.7 | Auto-reclose Applications..... | 60 |
| 3.7.1 | Reclose Time Setting | 60 |
| 3.7.2 | Reclaim Time Setting | 60 |
| 3.7.3 | Shots to Lockout Setting | 61 |
| 3.7.4 | Sequence Auto-reclosing | 61 |
| 3.8 | Trip Circuit Supervision | 61 |
| 3.9 | Output Relays | 62 |
| 3.10 | Post-fault Analysis..... | 62 |
| 3.10.1 | Events, Fault and Waveform Records | 62 |
| 3.10.2 | Fault triggers | 62 |
| 3.10.3 | Waveform triggers..... | 63 |
| 3.10.4 | ReyDisp (IEC 60870-5-103)..... | 63 |
| Section 4: Communication Interface..... | | 64 |
| 4.1 | Introduction | 64 |
| 4.1.1 | Comms Protocol Setting | 64 |
| 4.2 | IEC 60870-5-103..... | 64 |
| 4.2.1 | Physical Connection | 64 |
| 4.2.2 | Medium | 64 |
| 4.2.3 | Recommended cable | 64 |
| 4.2.4 | Network Topology | 65 |
| 4.2.5 | Settings | 65 |
| 4.2.6 | IEC Class II Measurands | 65 |
| 4.2.7 | IEC Class II Update period..... | 65 |
| 4.2.8 | IEC Class II scaling..... | 65 |
| 4.2.9 | Baud Rate..... | 65 |
| 4.2.10 | Comms Parity | 65 |
| 4.2.11 | Relay Address..... | 65 |
| 4.2.12 | Line Idle | 65 |
| 4.2.13 | Data Echo | 66 |
| 4.2.14 | Modems | 66 |
| 4.2.15 | Connecting a Modem to the Relay(s)..... | 66 |
| 4.2.16 | Setting the Remote Modem | 66 |
| 4.2.17 | Connecting to the Remote Modem | 67 |
| 4.3 | Introduction – Modbus RTU | 68 |
| 4.3.1 | Medium | 68 |
| 4.3.2 | Recommended cable | 68 |
| 4.3.3 | Network Topology | 68 |

| | | |
|--------|----------------------|----|
| 4.3.4 | Settings | 69 |
| 4.3.5 | Comms Protocol | 69 |
| 4.3.6 | Baud Rate | 69 |
| 4.3.7 | Comms Parity | 69 |
| 4.3.8 | Relay Address | 69 |
| 4.3.9 | Line Idle | 69 |
| 4.3.10 | Data Echo | 69 |
| 4.3.11 | Glossary | 70 |

List of Figures

| | | |
|---------------|---|----|
| Figure 1.5-1 | IDMTL Curves (Time Multiplier=1) | 16 |
| Figure 1.5-2 | Overcurrent Starter Operate Time to Contact | 17 |
| Figure 1.5-3 | Instantaneous Highset Operate Time to Contact | 17 |
| Figure 1.5-4 | Instantaneous Lowset Operate Time to Contact | 17 |
| Figure 1.5-5 | Sensitive Earth-fault Frequency Response (Is = 5 mA) | 18 |
| Figure 1.5-6 | Sensitive Earth-fault Operate Time to Contact | 18 |
| Figure 1.5-7 | Directional Timing Characteristic | 19 |
| Figure 2.1-1 | Overview of Argus Relay Protection Functions | 20 |
| Figure 2.3-1 | Functional Diagram – Characteristic Phase-fault Overcurrent Element | 27 |
| Figure 2.3-2 | Functional Diagram – Characteristic Earth-fault Overcurrent Element | 27 |
| Figure 2.3-3 | Functional Diagram – Instantaneous Phase-fault Overcurrent Elements | 28 |
| Figure 2.3-4 | Functional Diagram – Instantaneous Earth-fault Overcurrent Elements | 28 |
| Figure 2.4-1 | Functional Diagram – Sensitive Earth-fault/Restricted Earth-fault Elements | 30 |
| Figure 2.5-1 | Functional Diagram – Circuit Breaker Fail | 32 |
| Figure 2.5-2 | Functional Diagram – Current Transformer Fail | 33 |
| Figure 2.7-1 | Functional Diagram – Phase-fault Directional Element | 35 |
| Figure 2.7-2 | Functional Diagram – Earth-fault Directional Element | 35 |
| Figure 2.8-1 | Functional Diagram – Undervoltage/Overvoltage Element | 37 |
| Figure 2.11-1 | Status Input Logic | 46 |
| Figure 2.11-2 | Output Relay Logic | 46 |
| Figure 3.2-1 | Parallel Feeder Protection | 55 |
| Figure 3.4-1 | Blocking scheme giving fast fault clearance | 56 |
| Figure 3.4-2 | Busbar Zone Protection with Circuit Breaker Fail using Non-directional Relays. For use on Single-source Feed Networks | 57 |
| Figure 3.4-3 | Busbar Zone Protection with Circuit Breaker Fail Employing Bi-Directional relays. For use on fully Interconnected Networks with Remote Supply Sources | 58 |
| Figure 3.5-1 | Balanced and Restricted Earth-fault protection of Transformers | 59 |
| Figure 3.5-2 | Restricted Earth-fault Secondary Circuit | 59 |
| Figure 3.5-3 | Composite Overcurrent and Restricted Earth-fault Protection | 59 |
| Figure 3.8-1 | Engineering Recommendations S.15 H6 Trip Circuit Supervision scheme | 61 |
| Figure 3.8-2 | Engineering Recommendations S.15 H5 Trip Circuit Supervision scheme | 62 |
| Figure 4.2-1 | Communication to Argus Relay using Sigma 4 (Local Connection) | 67 |
| Figure 4.2-2 | Communication to Argus Relay using Sigma 4 and Modem | 67 |
| Figure 4.2-3 | Communication to Multiple Argus Relays from Control System and Laptop with Sigma 3 and Fibre-optic Ring Network | 67 |
| Figure 4.2-4 | Communication to Multiple Argus Relays from Control System and Laptop with Sigma 1 and Fibre-optic Star Network | 68 |
| Figure 4.3-1 | Communication to Argus Relay using Sigma 4 (Local Connection) | 69 |
| Figure 4.3-2 | Communication to Multiple Argus Relays from Control System and Laptop with Sigma 1 and Fibre-optic Star Network | 70 |
| Figure 4.3-3 | Communication to Argus Relay using RS485 – RS232 converter (Local Connection) | 70 |
| Figure 4.3-4 | Communication to Argus Relay using RS485/RS232 converter (Multidrop Connection) | 70 |

List of Tables

| | | |
|-----------|---|----|
| Table 2-1 | Overview of Functional Description Sections | 21 |
| Table 2-2 | Settings Group Settings | 22 |

| | | |
|------------|--|----|
| Table 2-3 | System Frequency Setting | 23 |
| Table 2-4 | Current and Voltage Input Settings | 23 |
| Table 2-5 | Identifier Setting | 24 |
| Table 2-6 | General Alarm Settings | 24 |
| Table 2-7 | Direction Settings | 25 |
| Table 2-8 | Real Time Clock Settings | 25 |
| Table 2-9 | Default Instrument Setting | 25 |
| Table 2-10 | Password Setting | 26 |
| Table 2-11 | Phase-fault and Earth-fault Overcurrent Settings | 28 |
| Table 2-12 | Flashing Fault Setting..... | 29 |
| Table 2-13 | Sensitive Earth-fault / Restricted Earth-fault Settings..... | 30 |
| Table 2-14 | Circuit Breaker Fail Settings | 32 |
| Table 2-15 | Current Transformer Fail Settings | 33 |
| Table 2-16 | Cold Load Pickup Settings | 34 |
| Table 2-17 | Directional Settings | 35 |
| Table 2-18 | Voltage Protection Settings | 37 |
| Table 2-19 | Auto-reclose from Internal Elements - Settings | 40 |
| Table 2-20 | Auto-reclose from External Trip Settings | 42 |
| Table 2-21 | Auto-reclose Commands Settings | 44 |
| Table 2-22 | Live Line Working Setting..... | 45 |
| Table 2-23 | Trip Circuit Supervision Settings | 45 |
| Table 2-24 | General Output Relay and Status Input Settings..... | 46 |
| Table 2-25 | List of Entries for Fault Data Records..... | 47 |
| Table 2-26 | Data Storage Settings | 49 |
| Table 2-27 | Circuit Breaker Maintenance Settings | 51 |
| Table 2-28 | Output Relay Test Setting | 51 |
| Table 2-29 | Internal Supervision Setting..... | 52 |
| Table 2-30 | Linesman Mode Setting..... | 53 |
| Table 2-31 | Linesman Mode Settings and Commands..... | 53 |
| Table 4-1 | Communications Settings..... | 66 |
| Table 4-2 | Communications Settings..... | 69 |

Section 1: Performance Specification

1.1 General

1.1.1 CE Conformity

This product is CE compliant to the following applicable EU directives.

Electromagnetic Compatibility Directive

CE 89/336/EEC

Compliance to the European Commission Directive on EMC is claimed via testing to the Harmonised Product Standard:- EN 50263:2000

Low voltage Directive

CE 73/23/EEC

Compliance to the European Commission Directive on LVD is claimed via testing to the Harmonised Product Standard:- EN 60255-5:2000

1.1.2 Reference

These products comply with the requirements of the IEC 60255-xx series and IEC 60068 standards and specifically with IEC 60255-3 and IEC 60255-12.

1.1.2.1 Accuracy Reference Conditions

This product has been tested under the following conditions, unless specifically stated otherwise.

| Parameter | Value | |
|---------------------|-------------|----------------|
| Current settings | 100 % I_n | |
| Time multiplier | 1.0 | |
| Current input | IDMTL | 2 to 30 xI_s |
| | DTL | 5 xI_s |
| Voltage input | 110 V | |
| Auxiliary supply | nominal | |
| Frequency | nominal | |
| Ambient temperature | 20 °C | |

1.1.3 Dimensions and Weights

Dimensions

| Parameter | Value | |
|--|---------|--------|
| Width | E4 case | 103 mm |
| | E6 case | 155 mm |
| | E8 case | 206 mm |
| Height | 177 mm | |
| Depth behind panel (including clearance for wiring) | 237 mm | |
| Projection (from front of panel) | 32 mm | |

See appropriate case outline and panel drilling drawing, as specified in Diagrams and Parameters document, for complete dimensional specifications.

Weights

| Parameter | Value | |
|------------|------------------|--------|
| Net weight | Argus 1, E4 case | 3.3 kg |
| | Argus 1, E6 case | 4.8 kg |
| | Argus 2, E4 case | 3.3 kg |
| | Argus 2, E8 case | 6.6 kg |
| | Argus 4, E6 case | 4.8 kg |
| | Argus 6, E8 case | 6.6 kg |

1.2 Energising Quantities

1.2.1 Characteristic Energising Quantities

| Parameter | Value |
|-------------------|-----------|
| Nominal frequency | 50, 60 Hz |

1.2.1.1 AC Current

Nominal Current and Measuring Range

| | Nominal | Measuring Range | |
|-------|---------|-----------------|-----------------|
| I_n | 1, 5 A | Phase and earth | $80 \times I_n$ |
| | | SEF/REF | $2 \times I_n$ |

Note. 1 A and 5 A nominal inputs are user selectable on each model.

Thermal Withstand

| Overload Period | Overload Current | | | |
|-----------------|------------------|-------|------------------|-------|
| | Phase and earth | | SEF/REF | |
| | 1A | 5A | 1A | 5A |
| continuous | $3.0 \times I_n$ | | $2.0 \times I_n$ | |
| 10 minutes | $3.5 \times I_n$ | | | |
| 5 minutes | $4.0 \times I_n$ | | | |
| 3 minutes | $5.0 \times I_n$ | | | |
| 2 minutes | $6.0 \times I_n$ | | | |
| 3 seconds | 57.7 A | 202 A | 37.5 A | 202 A |
| 2 seconds | 70.7 A | 247 A | 46 A | 247 A |
| 1 second | 100 A | 350 A | 65 A | 350 A |
| 1 cycle | 177 A | 618 A | 115 A | 618 A |

Burden

| Attribute | Value | | | |
|-----------|------------------------|-----------------------|-----------------------|-----------------------|
| | Phase and earth | | SEF/REF | |
| | 1A | 5A | 1A | 5A |
| AC Burden | $\leq 0.05 \text{ VA}$ | $\leq 0.2 \text{ VA}$ | $\leq 0.2 \text{ VA}$ | $\leq 0.4 \text{ VA}$ |
| Impedance | $\leq 0.05 \ \Omega$ | $\leq 0.01 \ \Omega$ | $\leq 0.2 \ \Omega$ | $\leq 0.02 \ \Omega$ |

1.2.1.2 AC Voltage

Argus 2 and Argus 6 relays only

Nominal Voltage and Range

| | Nominal | Operating Range |
|-------|---------|------------------|
| V_n | 110 V | 250 V continuous |

Burden

| | Attribute | Value |
|--|-----------|-------------------|
| | AC Burden | < 0.1 VA at 110 V |

1.2.2 Auxiliary Energising Quantity

Auxiliary Power Supply

| | Nominal | Operating Range |
|-----------|--------------|---------------------------------|
| V_{AUX} | 24, 30, 48 V | 18 to 60 VDC |
| | 110, 220 V | 88 to 280 VDC 100 to 130 VAC |

Burden

| | Attribute | Value | |
|--|-----------|---------------------|------|
| | DC Burden | Quiescent (typical) | 3 W |
| | | Maximum | 10 W |

Status (Digital) Inputs

| | Nominal | Operating Range |
|----------|----------|-------------------|
| V_{ST} | 30, 34 V | 18 to 37.5 VDC |
| | 48, 54 V | 37.5 to 60 VDC |
| | 110, 125 | 87.5 to 137.5 VDC |
| | 220, 250 | 175 to 280 VDC |

When relays with 48/54V status inputs are supplied for 110/125 V or 220/250 V working, external dropper resistors will be supplied listed in the table below. This will enable the status input performance specified below for the 48/54V status inputs to be achieved on 110/125 V or 220/250 V.

| Nominal Operating Voltage | Resistor Value; Rating |
|---------------------------|------------------------|
| 110, 125 V | 2K7 \pm 5 %; 2.5 W |
| 220, 250 V | 8K2 \pm 5 %; 6.0 W |

Performance

| Attribute | Value | |
|---|--|--------|
| Minimum DC current for operation | $V_{ST} = 30 - 54 \text{ V}$ | 10 mA |
| | $V_{ST} = 110 - 250 \text{ V}$ | < 5 mA |
| Reset/Operate voltage ratio | $\geq 90 \%$ | |
| Typical response time | 5 ms (10ms for ARGUS 2 type II) | |
| Typical response time when programmed to energise an output relay contact | < 15 ms | |
| Recommended Minimum pulse duration | 40 ms with setting of 20ms PU delay for a.c. rejection | |

Each status input has associated timers which can be programmed to give time delayed pick-up and time delayed drop-off. These timers have default settings of 20ms, thus providing rejection and immunity to an AC input signal.

Status inputs will not respond to the following:-

- 250V RMS 50/60Hz applied for two seconds through a 0.1 μ F capacitor.
- Discharge of a 10 μ F capacitor charged to maximum DC auxiliary supply voltage.

The status inputs with nominal voltage of 30 V to 54 V meet the requirements of ESI 48-4 ESI 1.

Low Burden Status Inputs

Optionally, low burden status inputs are available directly rated for 110/125Vd.c. or 220/250Vd.c. without dropper resistors. These inputs do not meet the ESI 48-4 ESI 1 requirements. Where necessary a single external dropper resistor in parallel can be fitted to meet ESI 48-4 ESI 1 requirements.

Low Burden Status Input performance

| | Nominal | Operating Range | Typical burden |
|--|----------|--------------------|-------------------|
| | 110, 125 | 87.5 to 137.5 V DC | 1.75 mA to 3.0 mA |
| | 220, 250 | 175 to 280 V DC | 1.75 mA to 3.0 mA |

110/125 V minimum pick-up voltage typically 50 – 60 V d.c.

220/250 V minimum pick-up voltage typically 100 – 120 V d.c.

1.3 Output Contacts

Contact rating to IEC 60255-0-20

| Attribute | | Value |
|---|--------------|--|
| Carry continuously | | 5 A AC or DC |
| Make and carry (L/R ≤ 40 ms and V ≤ 300 V) | for 0.5 s | 20 A AC or DC |
| | for 0.2 s | 30 A AC or DC |
| Break (≤ 5 A and ≤ 300 V) | AC resistive | 1250 VA |
| | AC inductive | 250 VA at p.f. ≤ 0.4 |
| | DC resistive | 75 W |
| | DC inductive | 30 W at L/R ≤ 40ms 50 W at L/R ≤ 10ms |
| Minimum number of operations | | 1000 at maximum load |
| Minimum recommended load | | 0.5 W at minimum of 10mA or 5V |

1.4 Functional Performance

1.4.1 Phase-fault Overcurrent Protection

A time-delayed characteristic (IDMTL, DTL) and 3 instantaneous/DTL characteristics (Lowset, Highset 1 and Highset 2) are provided.

1.4.1.1 Time Delayed Characteristic

Operate Level

| | Attribute | Value | |
|----------|---------------|---|-------|
| I_s | Setting range | 0.05, 0.1...2.50 x I_n | |
| I_{op} | Operate level | 105 % I_s , ± 4% or 1 % I_n | |
| | Reset level | 95 % I_{op} ± 5% or 1 % I_n | |
| | Repeatability | ± 5 % | |
| | Variation | -10 °C to +55 °C | ≤ 5 % |
| | | 47 Hz to 52 Hz 57 Hz to 62 Hz harmonics to 550 Hz | ≤ 5 % |

Operate Time

| | Attribute | Value |
|--------|------------------------------|---|
| | Starter operate time | See Figure 1.5-2, ± 5 ms |
| $char$ | Characteristic setting range | NI (IEC type A), VI (IEC type B), EI (IEC type C), LTI, DTL |

| | Attribute | Value |
|----------|--|--|
| T_m | Time multiplier setting range | 0.025, 0.050...1.600 |
| t_d | Delay setting range | 0.00, 0.01...20.00, 20.5 ...100, 101 ... 300 s |
| t_{op} | Operate time char = NI, VI, EI, LTI | $t = \frac{K}{\left[\frac{I}{I_s}\right]^\alpha - 1} \times T_m, \pm 5 \% \text{ absolute or } \pm 30 \text{ ms,}$ where I = applied current, for char = NI : $K = 0.14, \alpha = 0.02$ (IEC type A) VI : $K = 13.5, \alpha = 1.0$ (IEC type B) EI : $K = 80.0, \alpha = 2.0$ (IEC type C) LTI : $K = 120.0, \alpha = 1.0$ |
| | char = DTL | $t_d, \pm 1 \% \text{ or } \pm 10 \text{ ms}$ |
| | Repeatability | $\pm 1 \% \text{ or } \pm 10 \text{ ms}$ |
| | Overshoot time | < 40 ms |
| | Disengaging time | < 42 ms |
| | Reset setting | INST, 1, 2...60 s |
| | Variation 47 Hz to 52 Hz 57 Hz to 62 Hz harmonics to 550 Hz | $\leq 5 \%$ |

Figure 1.5-1 shows the operate times for the four IDMTL curves with a time multiplier of 1. Figure 1.5-2 shows the instantaneous operate times for the principal overcurrent starter. These operate times apply to non-directional characteristics. Where directional control is applied then the directional element operate time (section 1.4.4) should be added to give total maximum operating time.

1.4.1.2 Lowset, Highset 1, Highset 2

Operate Level

| | Attribute | Value |
|----------|--|--|
| I_s | Setting range | 0.05, 0.1...2.5, 3.0...52.5 x I_n |
| I_{op} | Operate level | 100 % x $I_s, \pm 5 \% \text{ or } 1 \% I_n$ |
| | Reset level | 95 % $I_{op} \pm 5 \% \text{ or } 1 \% I_n$ |
| | Repeatability | $\pm 5 \%$ |
| | Transient overreach (X/R ≤ 100) | $\leq 5 \%$ |
| | Variation -10 °C to +55 °C 47 Hz to 52 Hz 57 Hz to 62 Hz harmonics to 550 Hz | $\leq 5 \%$ |
| | | $\leq 5 \%$ |

Operate Time

| | Attribute | Value |
|-------------|--|---|
| t_{start} | Starter operate time | see Figure 1.5-3 and Figure 1.5-4, $\pm 5 \text{ ms}$ |
| t_d | Delay setting | 0.00, 0.01...20.00, 20.5 ...100, 101 ... 300 s |
| t_{op} | Operate time | $t_d + t_{start}, \pm 1 \% \text{ or } \pm 10 \text{ ms}$ |
| | Repeatability | $\pm 1 \% \text{ or } \pm 10 \text{ ms}$ |
| | Overshoot time | < 40 ms |
| | Disengaging time | < 42 ms |
| | Variation 47 Hz to 52 Hz 57 Hz to 62 Hz harmonics to 550 Hz | $\leq 5 \%$ |

Figure 1.5-3 and Figure 1.5-4 show the instantaneous highset and lowset outputs. These instantaneous operate times i.e. delay setting $t_d = 0.005$ apply to non-directional characteristics. Where directional control is applied then the directional element operate time (section 1.4.4) should be added to give total maximum operating time.

1.4.2 Earth-fault Overcurrent Protection

A main characteristic (IDMTL, DTL) and 3 DTL characteristics (Lowset, Highset 1 and Highset 2) are provided.

1.4.2.1 Time Delayed Characteristic

Specification as for phase-fault overcurrent (section 1.4.1.1).

1.4.2.2 Lowset, Highset 1, Highset 2

Specification as for phase-fault overcurrent (section 1.4.1.2).

1.4.3 Sensitive/Restricted Earth-fault Protection

A single element with three timing characteristics (lowset, DTL1 and DTL2) is provided.

Operate Level

| | Attribute | Value |
|-----------|------------------|--|
| I_s | Current setting | 0.005, 0.010...0.960 $\times I_n$ |
| I_{op} | Operate level | 100 % I_s , $\pm 5\%$ or 1 % I_n |
| | Reset level | 95 % I_{op} , $\pm 5\%$ or 1 % I_n |
| | Repeatability | $\pm 1\%$ |
| Variation | -10 °C to +55 °C | $\leq 5\%$ |
| | 47 Hz to 52 Hz | $\leq 5\%$ |
| | 57 Hz to 62 Hz | |

Note. SEF relays are required to suppress 2nd, 3rd and higher harmonics and have a frequency response at minimum setting as shown in Figure 1.5-5.

Operate Time

| | Attribute | Value |
|--|------------------------------------|--|
| t_{lowset} , t_{DTL1} , t_{DTL2} | Delay setting (lowset, DTL1, DTL2) | 0.00, 0.01...20.00, 20.5 ...100, 101 ... 300 s |
| Operating time | lowset | $t_{lowset} \pm 1\%$ or ± 10 ms |
| | DTL1 | $t_{DTL1} \pm 1\%$ or ± 10 ms |
| | DTL2 | $t_{DTL1} + t_{DTL2} \pm 1\%$ or ± 10 ms |
| | Repeatability | $\pm 1\%$ or ± 10 ms |
| | Overshoot time | < 40 ms |
| | Disengaging time | < 42 ms |
| Variation | 47 Hz to 52 Hz | $\leq 5\%$ |
| | 57 Hz to 62 Hz | |

Figure 1.5-6 shows the sensitive earth fault starter output. This instantaneous operate time applies to non-directional characteristics. Where directional control is applied then the directional element operate time (section 1.4.4) should be added to give total maximum operating time.

1.4.4 Directional Characteristics

Applies to Argus 2 and Argus 6 relays only.

Directional characteristics can be applied to phase-fault overcurrent elements, earth-fault overcurrent elements and single-pole sensitive earth-fault models.

Two types of directional element exist, referred to below as type I and type II. On a particular model the type of element in the relay can be identified from the range of the angle setting as listed below: -

Operate Angle

| | Attribute | | Value |
|------------|--|-----------------------------|--|
| θ_s | Angle setting | Phase-fault | type I: +30, +45 ° type II: -90, -89...0, +1...+90 ° |
| | | Earth-fault | type I: 0, -15, -45, -65 ° (see note below) type II: -90, -89...0, +1...+90 ° |
| CA | Characteristic angle (I with respect to V) | type I at 50 Hz, type II | $\theta_s, \pm 5^\circ$ |
| | | type I at 60 Hz | Phase-fault: $+25 \pm 5^\circ$ or $+40 \pm 5^\circ$ Earth-fault: $0 \pm 5^\circ, -13 \pm 5^\circ, -46 \pm 5^\circ$ or $-67 \pm 5^\circ$ |
| | Operating angle | forward | CA - $87.5^\circ \pm 5^\circ$ to CA + $87.5^\circ \pm 5^\circ$ |
| | | reverse | (CA - 180°) - $87.5^\circ \pm 5^\circ$ to (CA - 180°) + $87.5^\circ \pm 5^\circ$ |
| | Variation in characteristic angle | 10°C to +55°C | $\pm 5^\circ$ |
| | | 47 Hz to 52 Hz | type I: $\pm 2.5^\circ$ per 5 Hz variation |
| | | 57 Hz to 62 Hz | type II: $\pm 2.5^\circ$ |

Note. Some models are available in which the -65 ° setting is replaced by a -90 ° setting.

Operate Threshold

| | Attribute | | Value |
|--|------------------------------|---------|----------------------|
| | Minimum levels for operation | I | > 5 % I _n |
| | | V (p/f) | > 2 V |
| | | V (e/f) | > 3.3 V |

Operate Time

| | Attribute | Value |
|--|--------------|---|
| | Operate time | type I: typically 20 ms at characteristic angle type II: typically 40 ms at characteristic angle |
| | Reset time | type I: typically 20 ms at characteristic angle type II: typically 40 ms at characteristic angle |

See Figure 1.5-7.

1.4.5 Circuit Breaker Fail**Operate Level**

| | Attribute | Value |
|----------|---------------------|---|
| I_s | Phase Fault setting | Off, 0.05, 0.1 ... 1.0 x I _n |
| I_s | Earth Fault Setting | Off, 0.05, 0.1 ... 1.0 x I _n |
| I_s | SEF Setting | Off, 0.05, 0.1 ... 1.0 x I _n |
| I_{op} | Operate Level | 100 % $I_s \pm 5\%$ or 1 % I _n |
| | Reset Level | 95 % $I_{op}, \pm 5\%$ or 1 % I _n |
| | Repeatability | $\pm 1\%$ |
| | Variation | 47 Hz to 52 Hz 57 Hz to 62 Hz harmonics to 550 Hz $\leq 5\%$ |

Operate Time

| | Attribute | Value |
|---------------------------|----------------------------------|--|
| $t_{CBF1},$ t_{CBF2} | Delay setting (retrip, backtrip) | 0.00, 0.01...20.00, 20.5 ...100, 101 ... 300 s |

| Attribute | Value |
|------------------|--|
| Operating time | retrip $t_{CBF1}, \pm 1 \% \text{ or } \pm 10 \text{ ms}$ |
| | backtrip $t_{CBF1} + t_{CBF2}, \pm 1 \% \text{ or } \pm 10 \text{ ms}$ |
| Repeatability | $\pm 1 \% \pm 10 \text{ ms}$ |
| Overshoot time | $< 40 \text{ ms}$ |
| Disengaging time | $< 42 \text{ ms}$ |

1.4.6 Auto-reclose

Integrated with the Overcurrent, Low Set, Delay and High Set 1 and High Set 2 elements.

| Attribute | Value |
|---------------------------|--|
| Number of reclose shots | up to 4 (separate for phase-fault, earth-fault, SEF and external) |
| Timers | Reclose DTL 1, 2, 3, 4; Reclaim time (separate for phase-fault, earth-fault, SEF and external) |
| Timer ranges | 0.20, 0.21...2.0, 2.1...20, 21...300, 360...3600, 3900...14400 s |
| Time accuracy, all timers | setting $\pm 1 \% \text{ or } 10 \text{ ms}$ |
| Repeatability | $\pm 1 \%$ |

1.4.7 Instrumentation

Voltage, power and power factor instruments are available on Argus 2 type II models only.

| | Instrument Value | Reference | Typical accuracy | Claimed accuracy |
|------|--------------------------|---|------------------|---|
| I | Current | $I \geq 0.1 \times I_n$ | $\pm 1 \% I_n$ | $\pm 3 \% I_n$ |
| V | Voltage | $V \geq 0.8 \times V_n$ | $\pm 1 \% V_n$ | $\pm 3 \% V_n$ |
| | Power, real and apparent | $V = V_n, I \geq 0.1 \times I_n, pf \geq 0.8$ | | $\pm 3 \% P_n$, where $P_n = V_n \times I_n$ |
| pf | Power factor | $V = V_n, I \geq 0.1 \times I_n, pf \geq 0.8$ | | ± 0.05 |

1.4.8 Communication Interface

| Attribute | Value |
|---------------------------------------|--|
| Physical layer | Fibre-optic (option EIA RS-485) |
| Connectors | ST TM (BFOC/2.5) (RS-485 electrical 4mm terminal) |
| Recommended fibre | 62.5/125 μm glass fibre with ST TM connector |
| Launch power (into recommended fibre) | -16 dBm |
| Receiver sensitivity | -24 dBm |
| Protocol | IEC 60870-5-103 or MODBUS RTU |

'ST' is the registered trade mark of AT&T Co.

1.4.9 Real Time Clock

| Attribute | Value |
|-----------|---|
| Accuracy | $\pm 50 \text{ ppm}$ (equivalent to $\pm 180 \text{ ms per hour}$) |

1.5 Environmental Performance

1.5.1 General

1.5.1.1 Temperature

IEC 60068-2-1/2

| Type | Level |
|-----------------|------------------|
| Operating range | -10 °C to +55 °C |
| Storage range | -25 °C to +70 °C |

1.5.1.2 Humidity

IEC 60068-2-3

| Type | Level |
|------------------|---|
| Operational test | 56 days at 40 °C and 95 % relative humidity |

1.5.1.3 Insulation

IEC 60255-5

| Type | Level |
|--------------------------------|-------------------------|
| Between any terminal and earth | 2.0 kV AC RMS for 1 min |
| Between independent circuits | |
| Across normally open contacts | 1.0 kV AC RMS for 1 min |

1.5.1.4 IP Ratings

| Type | Level |
|------------------------------|-------|
| Installed with cover on | IP 51 |
| Installed with cover removed | IP 30 |

1.5.2 Immunity

1.5.2.1 Auxiliary DC Supply Variation

| Quantity | Value |
|--|---------------------|
| Allowable superimposed ac component | ≤ 12% of DC voltage |
| Allowable breaks/dips in supply (collapse to zero from nominal voltage) | ≤ 20ms |

1.5.2.2 High Frequency Disturbance

IEC 60255-22-1 Class III

| Type | Level | Variation |
|----------------------------|--------|-----------|
| Common (longitudinal) mode | 2.5 kV | ≤ 3 % |
| Series (transverse) mode | 1.0 kV | |

1.5.2.3 Electrostatic Discharge

IEC 60255-22-2 Class III

| Type | Level | Variation |
|-------------------|--------|-----------|
| Contact discharge | 8.0 kV | ≤ 5 % |

1.5.2.4 Radiated Radio Frequency Interference

IEC 60255-22-3 Class III

| Type | Level | Variation |
|--------------------|--------|-----------|
| 20 MHz to 1000 MHz | 10 V/m | ≤ 5 % |

1.5.2.5 Fast Transients

IEC 60255-22-4 Class IV

| Type | Level | Variation |
|----------------------------|-------|-----------|
| 5/50 ns 2.5 kHz repetitive | 4kV | ≤ 3 % |

1.5.2.6 Surge Immunity

IEC 60255-22-5

| Type | Level | Variation |
|--|--|------------|
| Between all terminals and earth, or between any two independent circuits | 4.0 kV, 1.2/50 μ s or 8/20 μ s | $\leq 5\%$ |

1.5.2.7 Conducted Radio Frequency Interference

IEC 60255-22-6

| Type | Level | Variation |
|----------------|-------|------------|
| 0.15 to 80 MHz | 10 V | $\leq 5\%$ |

1.5.3 Emissions

1.5.3.1 Radiated Radio Frequency Interference

IEC 60255-25

| Type | Limits at 10 m, Quasi-peak |
|------------------|----------------------------|
| 30 to 230 MHz | 40 dB(μ V) |
| 230 to 10000 MHz | 47 dB(μ V) |

1.5.3.2 Conducted Radio Frequency Interference

IEC 60255-25

| Type | Limits | |
|-----------------|-----------------|-----------------|
| | Quasi-peak | Average |
| 0.15 to 0.5 MHz | 79 dB(μ V) | 66 dB(μ V) |
| 0.5 to 30 MHz | 73 dB(μ V) | 60 dB(μ V) |

1.5.4 Mechanical

1.5.4.1 Vibration (Sinusoidal)

IEC 60255-21-1 Class I

| Type | Level | Variation |
|---------------------|--------|------------|
| Vibration response | 0.5 gn | $\leq 5\%$ |
| Vibration endurance | 1.0 gn | |

1.5.4.2 Shock and Bump

IEC 60255-21-2 Class I

| Type | Level | Variation |
|-----------------|--------------|------------|
| Shock response | 5 gn, 11 ms | $\leq 5\%$ |
| Shock withstand | 15 gn, 11 ms | |
| Bump test | 10 gn, 16 ms | |

1.5.4.3 Seismic

IEC 60255-21-3 Class I

| Type | Level | Variation |
|------------------|-------|------------|
| Seismic response | 1 gn | $\leq 5\%$ |

1.5.4.4 Mechanical Classification

| Type | Level |
|------------|---------------------|
| Durability | $> 10^6$ operations |

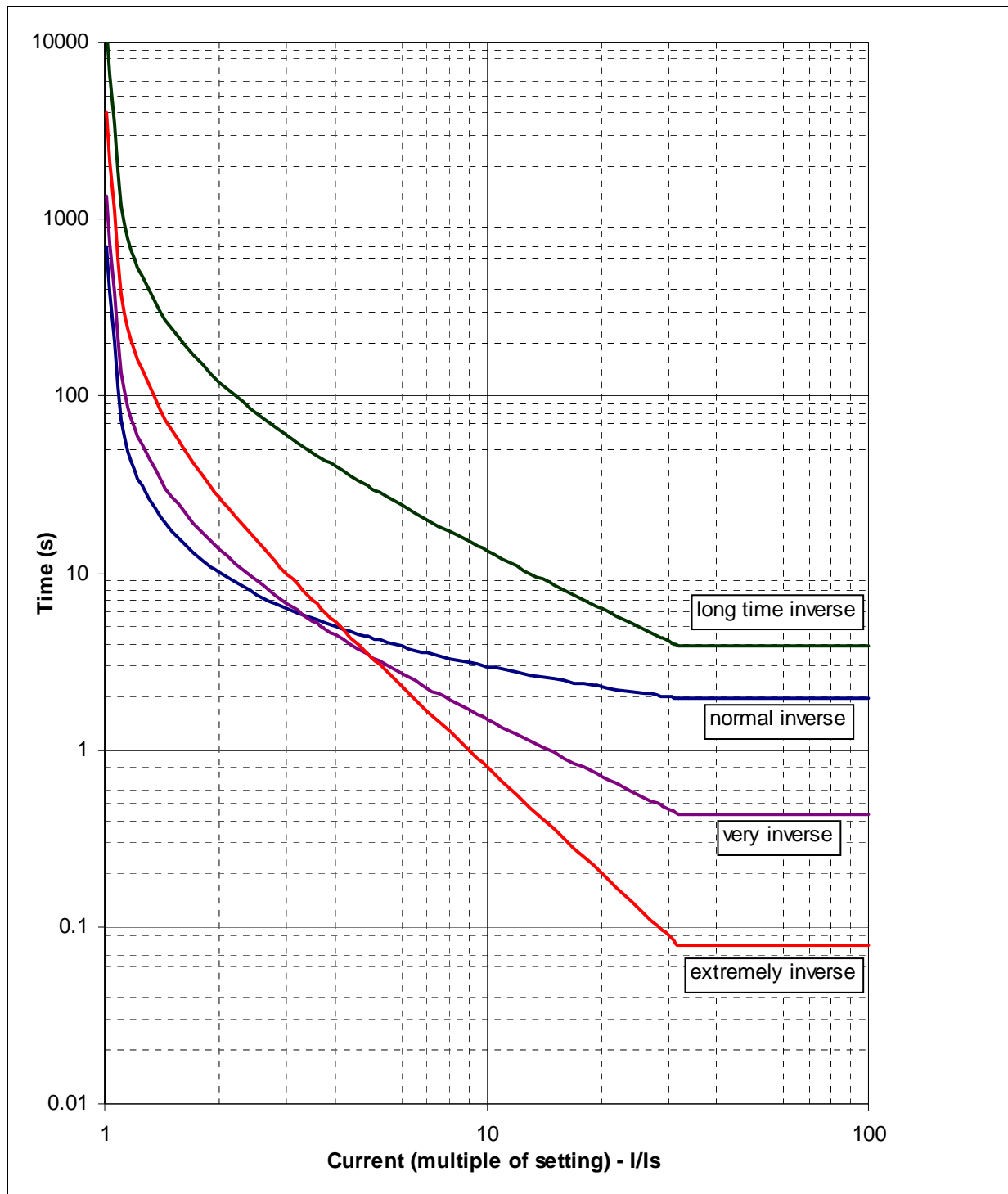

Figure 1.5-1 IDMTL Curves (Time Multiplier=1)

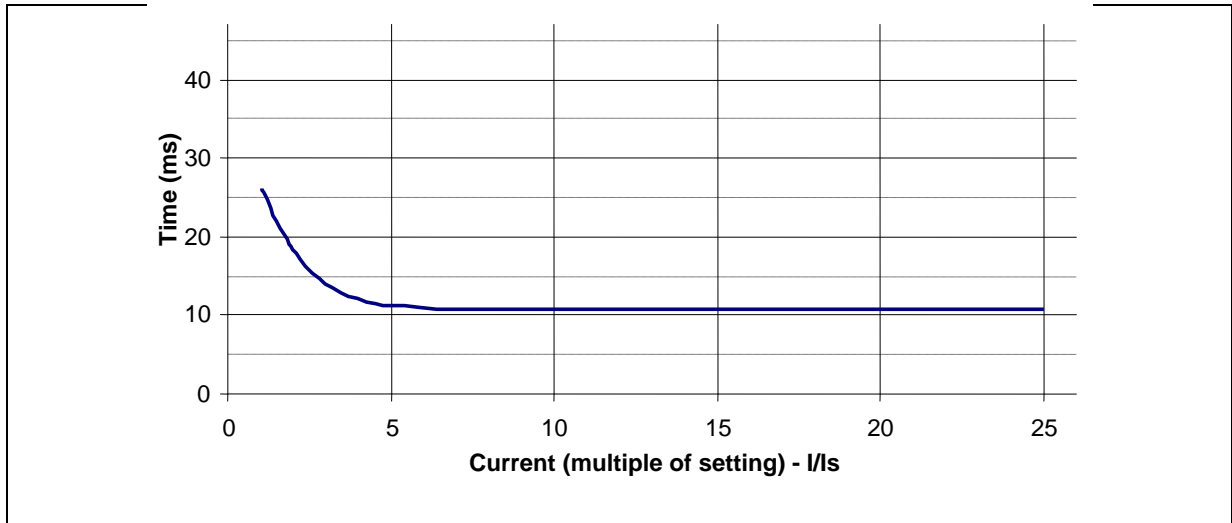

Figure 1.5-2 Overcurrent Starter Operate Time to Contact

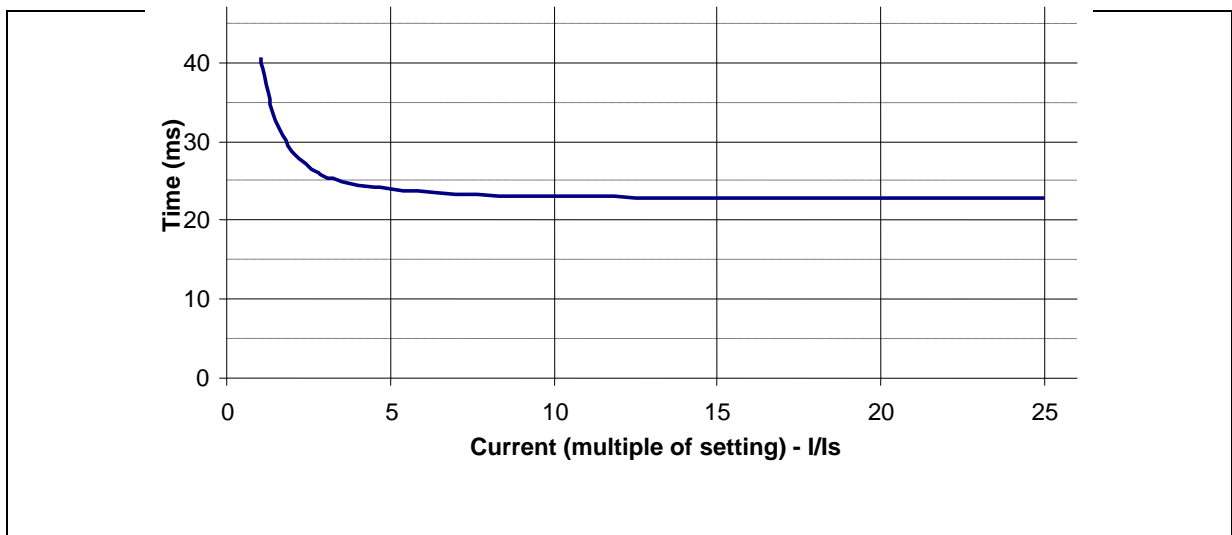

Figure 1.5-3 Instantaneous Highset Operate Time to Contact

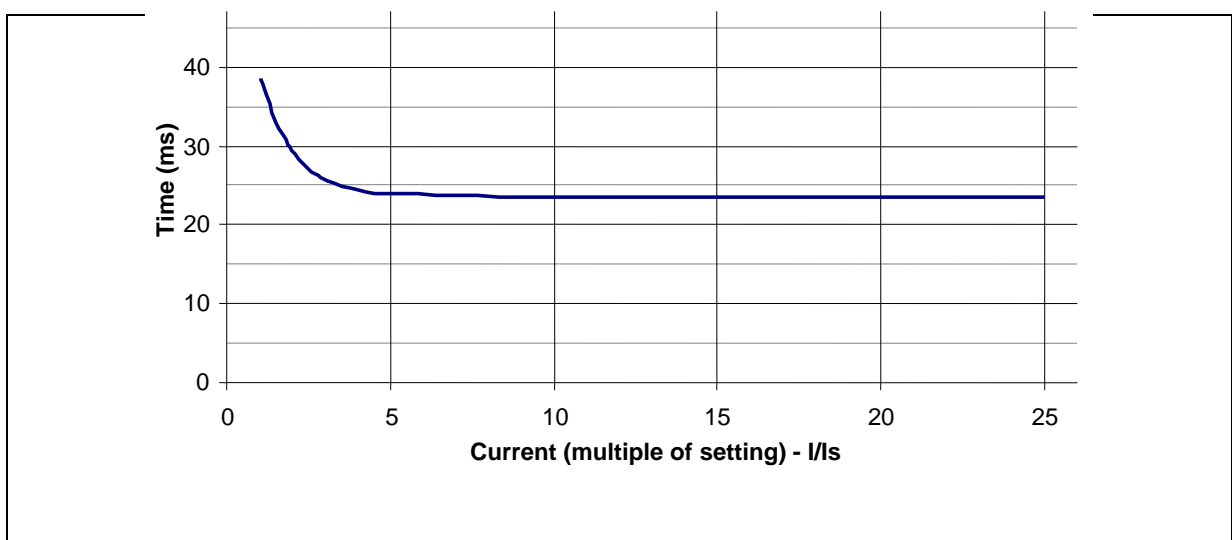

Figure 1.5-4 Instantaneous Lowset Operate Time to Contact

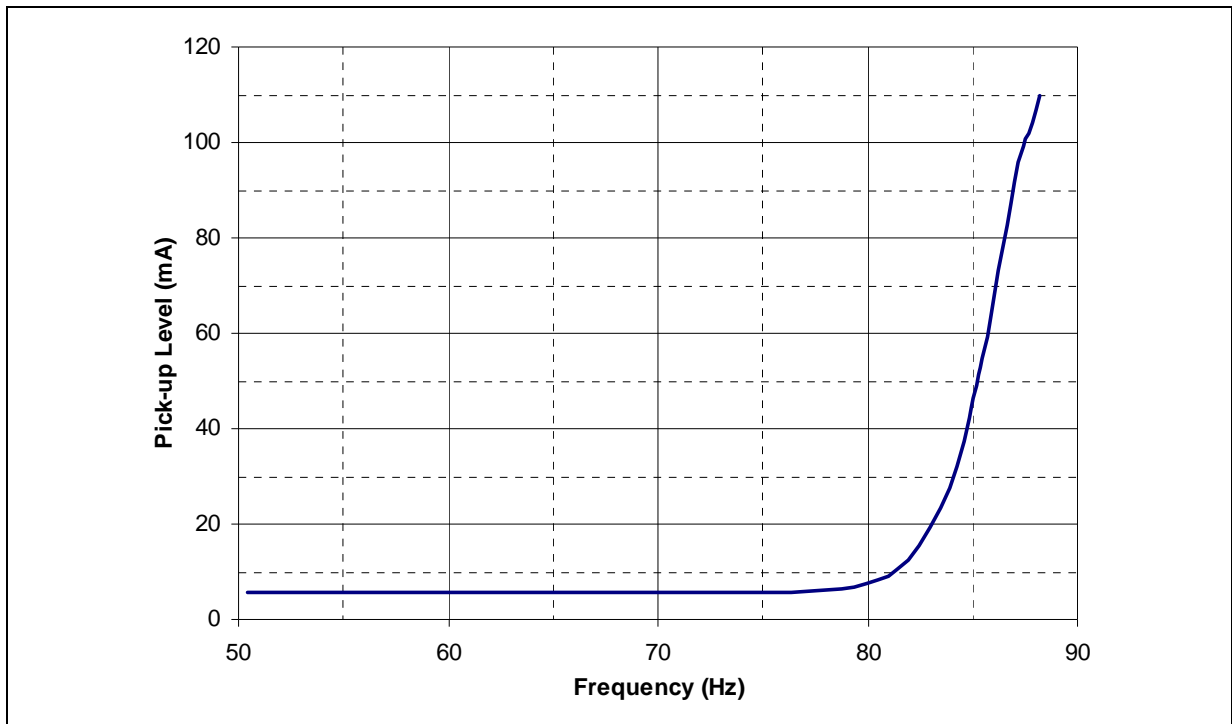

Figure 1.5-5 Sensitive Earth-fault Frequency Response ($I_s = 5$ mA)

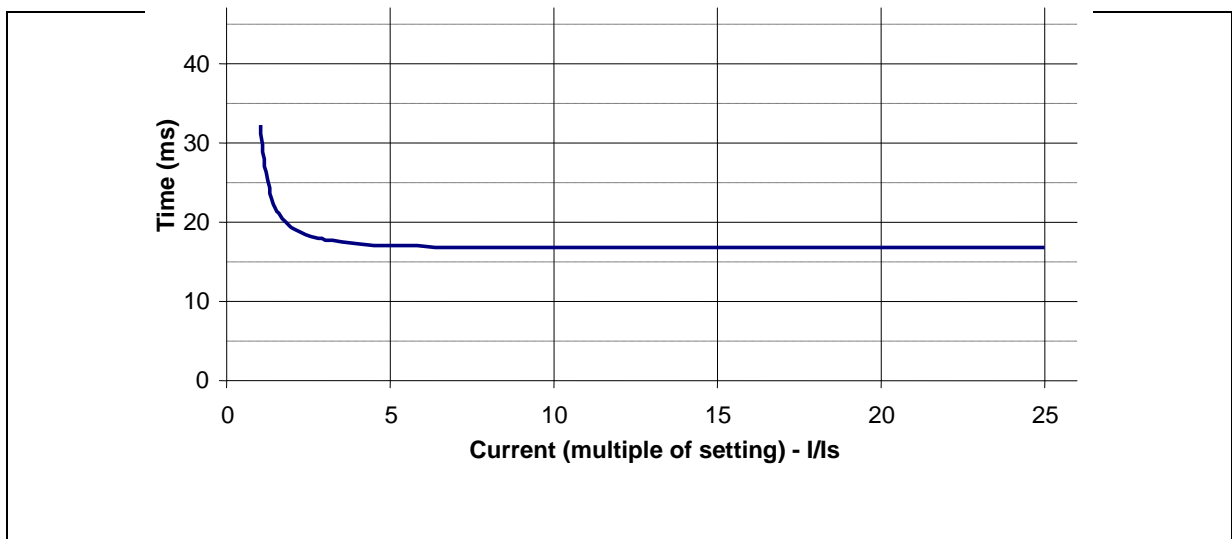

Figure 1.5-6 Sensitive Earth-fault Operate Time to Contact

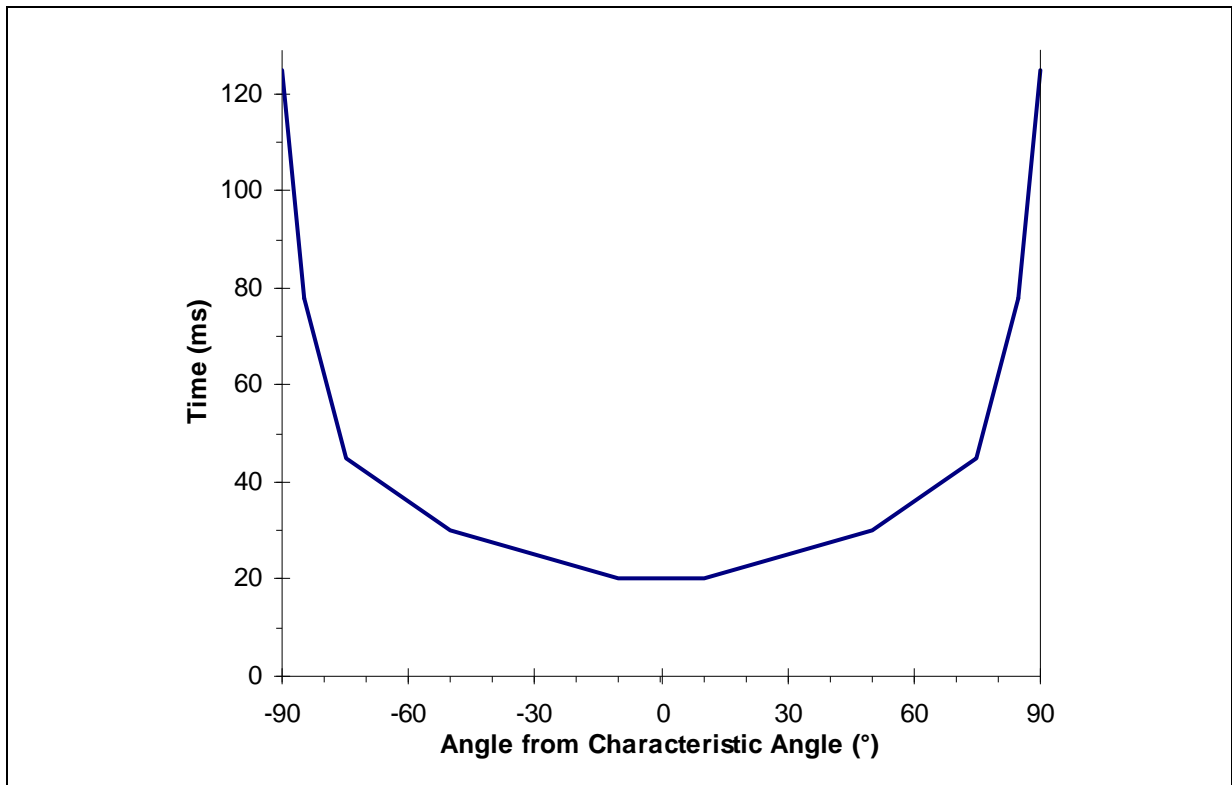

Figure 1.5-7 Directional Timing Characteristic

Section 2: Functional Description

2.1 Introduction

The Argus overcurrent relays incorporate a range of protection elements and functions that, together with the integrated control, automation, display and communication functions, provide comprehensive protection for application in distribution substations or backup protection on transmission feeders.

The protective functions that can be provided are shown in Figure 2.1-1, together with the analogue and digital input signals and outputs.

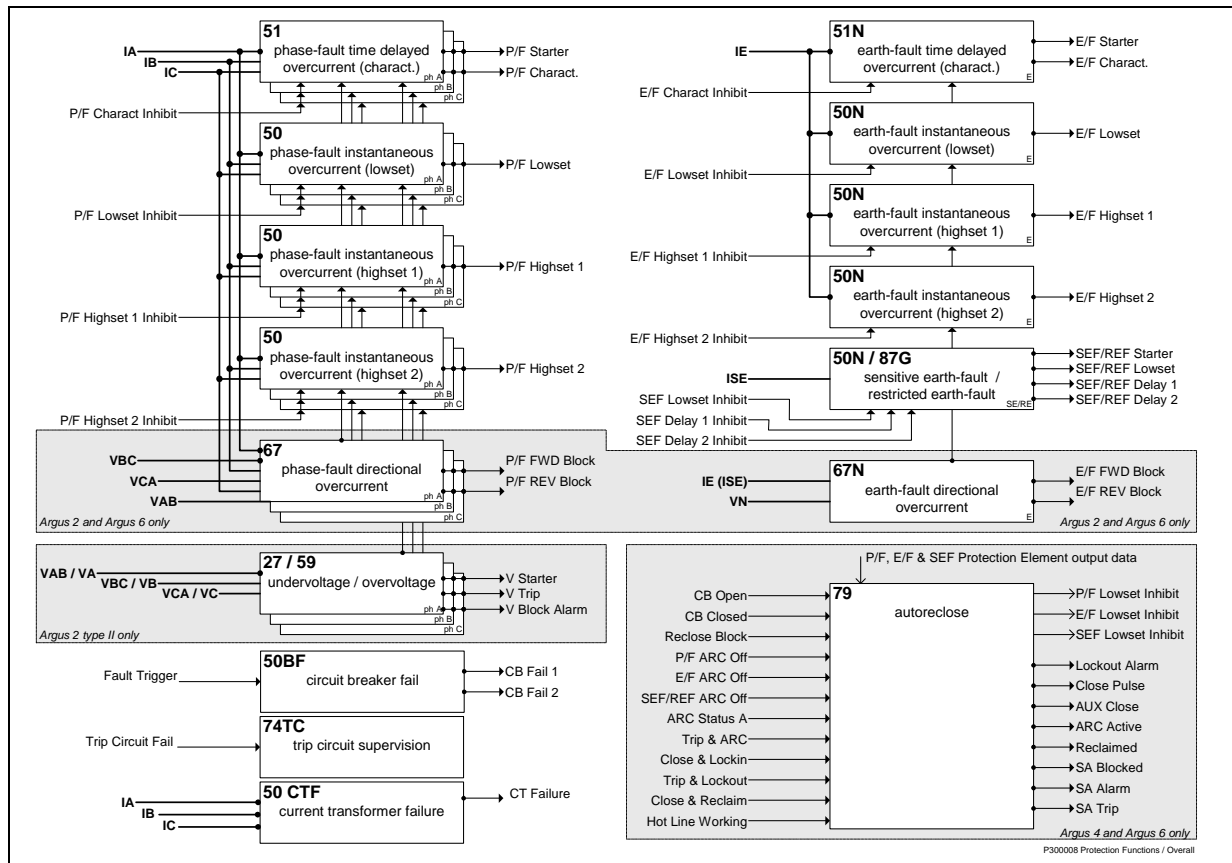

Figure 2.1-1 Overview of Argus Relay Protection Functions

Scaled analogue inputs are derived via input transformers. Control/inhibit input signals and output relays can be user mapped to be raised from any one, or more, status inputs; similarly, protection, alarm and control element outputs can be user mapped to output relays. The user can thus create an individual Input/Output matrix mapping specific to each installation. Each status input can be set to be inverted and/or latched and have pick-up and drop-off delay times set. Each output relay may be individually set to be latched (Hand Reset).

The flexibility of this input/output mapping coupled to the Protection and Control functions and Settings Group selection enables users to integrate scheme functions into the ARGUS Relay to produce a sophisticated protective device

Each of the functions shown in Figure 2.1-1 is described in the relevant sections below.

2.1.1 Models

A variety of Argus overcurrent protection models is available. Different combinations of the functions shown in Figure 2.1-1 are provided in each model to achieve different protective requirements.

Four series of relays are provided within the range:

- Argus 1 – overcurrent protection
- Argus 2 – directional overcurrent protection
- Argus 4 – overcurrent protection and integrated autoreclose
- Argus 6 – directional overcurrent protection and integrated autoreclose

Two types of current input circuits are used in the Argus range. One is used for phase-fault (P/F) and earth-fault (E/F) protection. The second type provides harmonic filtering and is used for sensitive earth-fault (SEF) and restricted earth-fault (REF) protection.

Two types of directional/voltage inputs are used in the Argus 2 series. Type I provides a fixed set of characteristic angles; type II allows any angle to be set and provides a voltage protection element and voltage and power measurands. Argus 6 series relays all have a type I voltage input.

The Diagrams and Parameters document for each series lists explicitly the functions that are provided within each model.

2.1.2 Document Organisation

The remainder of Section 2: Functional Description is organised as follows:

Table 2-1 Overview of Functional Description Sections

| Section | | Principal Setting Menus | Description |
|---------|--|---|--|
| 2.2 | Configuration | <i>System Config.</i> | Configuration of Argus for system requirements: system frequency, CT/VT ratios, identifiers, password etc. |
| 2.3 | Phase-Fault and Earth-fault Overcurrent | <i>Protection</i> | 51 phase-fault time delayed overcurrent (charact.) 50 phase-fault instantaneous overcurrent (lowset) 50 phase-fault instantaneous overcurrent (highset 1) 50 phase-fault instantaneous overcurrent (highset 2) 51N earth-fault time delayed overcurrent (charact.) 50N earth-fault instantaneous overcurrent (lowset) 50N earth-fault instantaneous overcurrent (highset 1) 50N earth-fault instantaneous overcurrent (highset 2) |
| 2.4 | Sensitive Earth-fault and Restricted Earth-fault | <i>Protection</i> | 50N sensitive earth-fault, or 87G restricted earth-fault |
| 2.5 | Circuit Breaker Fail | <i>Protection</i> | 50BF circuit breaker fail |
| 2.6 | Cold Load Protection | <i>System Config. + Auto-reclose</i> | Application of different settings group when energising a cold load. |
| 2.7 | Directional | <i>Directional</i> | 67 phase-fault directional overcurrent 67N earth-fault directional overcurrent |
| 2.8 | Voltage Protection | <i>Voltage</i> | 27/59 undervoltage/overvoltage protection |
| 2.9 | Auto-reclose | <i>Auto-reclose</i> | 79 auto-reclose |
| 2.10 | Trip Circuit Supervision | <i>Status Config.</i> | 74TC trip circuit supervision |
| 2.11 | Status Inputs and Relay Outputs | <i>Status Config. + O/P Relay Config.</i> | Pick-up and drop-off timers, inversion, latching and minimum energise time. |
| 2.12 | Communications | <i>Communications</i> | Communication with PC or control system. |
| 2.13 | Data Storage | <i>Data Storage</i> | Event, fault and waveform records. |
| 2.14 | Maintenance | <i>CB Maintenance</i> | Assistance for maintenance of circuit breakers, protection schemes and the Argus relay. |
| 2.15 | Linesman | <i>Linesman Mode</i> | Enables easy enabling/disabling of protection and auto-reclosing for line work. |

Notes

1. Within Section 2: Functional Description the following notational and formatting conventions are used:

- Item in menu structure: *Item*
- Setting: *sub-menu:setting name*
- Setting value: *value*
- Alternatives: [1st] [2nd] [3rd]

2. The purpose of this document is to describe the capabilities and functionality of the Argus Overcurrent Protection relays. The User Manual document describes how to set up and operate the Argus: apply configuration, settings and passwords, view instruments and set default instruments, and retrieve fault data.

2.2 Configuration

This section provides advice for configuring the Argus relay via the *Settings MODE - System Config.* menu to suit the overall requirements of the system and the protection scheme: e.g. system frequency, CT/VT ratios, identifiers, user alarm text, date & time, password, etc.

2.2.1 Settings Groups

Settings groups are used to parameterise the protection and configuration of the Argus relay. Eight Groups each containing a completely independent set of setting values can be stored in the relay, only the designated Group as set in *System Config:Active Setting Group = Gn* will be active i.e. applied, at a time. Examples of uses for settings groups: i.e. summer and winter settings, cold load settings, alternative settings values to cover special temporary situations, test settings, embedded generation in/out settings etc.

Some settings are common across all groups e.g. Relay Identifier etc. Settings that can be set to a unique value in each group have a setting description beginning with *Gn*, where *n* is the number of the Group currently being displayed e.g. *G1*. The settings in any Group can be accessed for editing via *System Config:Settings group Edit/View = Gn* including the currently Active Group; it is, however, strongly recommended that editing of settings is only done in a setting group that it is off-line i.e. not-active.

To assist in the parameterisation of different settings groups, where only a few settings differ, after entering user settings into one group the completed set of setting values can be copied from that group to another using the *System Config:Copy Group From Gn to Gx* setting, note that settings cannot be copied to the currently active group. Necessary settings changes may then be implemented.

Any group as set in *Status Config:Settings Group Select* can be selected dynamically, while the Relay is in-service, by raising the designated status input. When that status input is cleared, the settings group reverts to the previously active group, as specified by another status input or *System Config:Active Settings Group*. If more than one status input is raised at the same time, the group associated with the lowest number status input takes precedence. e.g. Status 2 - Group 8 takes precedence over Status 3 - Group 2. Change of group takes typically 15 ms but less than 17.5 ms.

Argus 2 - 500 series relays with a type II voltage input can also be programmed to change settings group on the operation of the voltage element, forcing a group change regardless of any starters which may be raised. This function can be used to set-up the Argus 2 to implement Voltage Controlled Overcurrent operation. Change of group takes typically 40 ms but less than 50 ms.

Table 2-2 Settings Group Settings

Sub-menu: **System Config.**

| Setting name | Range (bold = default) | Units | Notes |
|---------------------------------|---------------------------------|-------|-------|
| Active Settings Group | 1,2...8 | | |
| Settings Group Edit/View | | | |
| Copy Group | From 1,2...8 to 1,2...8 | | |

Sub-menu: **Status Config.**

| Setting name | Range (bold = default) | Units | Notes |
|------------------------------|--|-------|--|
| Settings Group Select | _, 1, 2...8 for each status input (and Vop) (default: _ _ _ _ _ _ _ _ _ _) | | <i>Argus 2 type II relays can change settings group from operation of the voltage element.</i> |

2.2.2 System Frequency

The relay can be user set for nominal 50 Hz or 60 Hz operation using *System Config:Power System Frequency*.

Table 2-3 System Frequency SettingSub-menu: **System Config.**

| Setting name | Range (bold = default) | Units | Notes |
|-------------------------------|---------------------------------|-------|-------|
| Power System Frequency | 50, 60 | Hz | |

2.2.3 Current and Voltage Inputs

Input Type Selection

On 3-pole models and 4-pole models with an SEF/REF input, the user can set the 'pole B' current input to be either the phase-fault B input (P/F) or an earth-fault input (E/F) using the *System Config.:Set Pole B Type* setting. When the input is set to P/F all settings related to the earth-fault will be hidden from view.

When an SEF/REF input is provided, its designation can be set to show 'SEF' or 'REF' using the *System Config.:Earth Fault Mode Select* setting. This changes only the text identifier which appears in various locations within the menu system, not the functionality of the element.

Phase Rotation

The setting *System Config.:Phase Rotation* allows the user to select the applicable system phase rotation.

Ratings and CT/VT Ratios

The current input for each pole can be user selected for operation from a 1A or 5A CT secondary. The appropriate connections are made on the relay terminals. The appropriate rating should be set using the *System Config.:P/F [E/F] [SEF/REF] Rating (In)* settings to allow the Argus to correctly calculate the measured current for display purposes. This setting will not affect the Protection Menu setting's display if they are displayed as xIn, however see Current Display Bases below.

CT and VT ratios can be set, allowing the relay to calculate primary currents and voltages for display.

VT settings appear on Argus 2 relays with type II directional elements only. In addition to the VT ratio setting a VT connection setting allows a three phase-earth VT to be used, with the relay calculating the neutral voltage internally.

Current Display Bases

The *System Config.:Current Display* setting allows the overcurrent protection settings to be displayed in primary amps, secondary amps, or xIn i.e. multiple of relay nominal current. The user can thus enter settings in the most convenient units. The Argus will perform the necessary conversion if the display units are changed.

Note. For the Argus to correctly calculate these values, the nominal CT Secondary Ratings and CT Ratios must be correctly entered, see above.

Table 2-4 Current and Voltage Input SettingsSub-menu: **System Config.**

| Setting name | Range (bold = default) | Units | Notes |
|--|---|-------|---------------------------------------|
| Set Pole B Type | P/F, E/F | | <i>Some Argus 1 and 2 models only</i> |
| Earth Fault Mode Select | SEF, REF | | <i>Models with SEF only</i> |
| Phase Rotation | A-B-C, A-C-B | | <i>Argus 2 (type II) only</i> |
| P/F Rating (In) E/F Rating (In) SEF/REF Rating (In) | 1, 5 | A | |
| P/F CT Ratio E/F CT Ratio SEF/REF CT Ratio | 5, 10, 15... 300 ...10000 : 1, 5 | | |
| VT Connection | Ph-N, Ph-Ph | | |
| VT Primary | 0, 1...9 for each of 6 digits (default: 11000) | V | <i>Argus 2 (type II) only</i> |
| VT Secondary | 40.0, 40.1...70.0, 70.5... 110.0 ...150.0 | V | |
| Current Display | xIn, PRIMARY, SECONDARY | | |

| Setting name | Range (bold = default) | Units | Notes |
|-----------------------------|---|-------|-------|
| Export power / lag VAR Sign | +ve/+ve , +ve/-ve, -ve/+ve, -ve/-ve, | | |

2.2.4 Identifier

User defined identifying text can be programmed into the relay using the *System Config.:Set Identifier* setting. This text is displayed on the title screen of the Argus and is used in communications with ReyDisp to identify the Argus relay.

Table 2-5 Identifier Setting

Sub-menu: **System Config.**

| Setting name | Range (bold = default) | Units | Notes |
|----------------|---|-------|---------------------|
| Set Identifier | ABCDEFGHIJKLMNQRSTU WXYZ1234567890 -+/ (default = ARGUS n e.g. ARGUS 1) | | Up to 16 characters |

2.2.5 General Alarms

General Alarms are user-defined text messages displayed on the LCD when mapped status inputs are raised. Up to five general alarms can be programmed, however this is limited by the number of status inputs on the device. Each general alarm can be triggered from one or more status inputs, as programmed by the appropriate setting.

The *System Config.:SET Alarm n* setting (where *n* is the alarm number) allows the user to programme a text message which is displayed on the LCD when the associated status inputs are raised, as set by *Status Config.:Alarm n*. The general alarm will also generate an event. If it is wished to operate an output contact for the alarm this can be programmed using the status input to output relay mapping (section 2.11).

If multiple alarms are active simultaneously the messages are linked in series in a rolling display on the LCD, separated by a '+' character. If it is necessary to display alarm messages longer than 13 characters then a status input may be mapped to multiple alarms, in which case a longer message will result.

All general alarms raised when a Fault Trigger is generated will be logged into the Fault Data record, transient general alarms will thus be latched and displayed at the end of the scrolling 'Fault Data' screen, see section 2.13.2

Table 2-6 General Alarm Settings

Sub-menu: **System Config.**

| Setting name | Range (bold = default) | Units | Notes |
|--|---|-------|------------------------------|
| SET Alarm 1 SET Alarm 2 ... SET Alarm 5 | ABCDEFGHIJKLMNQRSTU VWXYZ 1234567890 -+/ (ALARM n) | | Up to 13 characters per name |

Sub-menu: **Status Config.**

| Setting name | Range (bold = default) | Units | Notes |
|---|--|-------|------------------------------------|
| Gn Alarm 1 Gn Alarm 2 ... Gn Alarm 5 | mappable to any status input (default= _____) | | Default - not mapped to any status |

2.2.6 Direction Tags

Argus 2 and Argus 6 only

User defined text names for the Forward and Reverse directions can be applied to assist in identification of fault direction. For example, 'FWD' could be renamed 'FEEDER X', and 'REV' renamed 'BUSBAR Y'.

Note: Directional Relay convention is such that current flowing away from a busbar flows in the Forward direction.

These identifiers are used in the fault records to identify the direction of the fault.

Table 2-7 Direction SettingsSub-menu: **System Config.**

| Setting name | Range (bold = default) | Units | Notes |
|---------------------|---|-------|--|
| FWD Name Tag | ABCDEFGHIJKLMN OP QRSTU VWXYZ1234567890 -+/ (FWD) | | <i>Argus 2 and Argus 6 only Up to 13 characters per name</i> |
| REV Name Tag | ABCDEFGHIJKLMN OP QRSTU VWXYZ1234567890 -+/ (REV) | | |

2.2.7 Real Time Clock

The date and time can be programmed and then maintained by the internal real time clock. The clock is also maintained for 2-3 week while the relay is de-energised. Additionally, in order to maintain synchronism within a substation, all Argus relays can be synchronised to the nearest second or minute using a mapped status input or via the IEC 60870-5-103 protocol Time Synchronising Frame.

The *System Config.:Clock Sync. From Status* setting specifies whether the clock will be synchronised to the nearest minute or second when the status input is activated.

Table 2-8 Real Time Clock SettingsSub-menu: **System Config.**

| Setting name | Range (bold = default) | Units | Notes |
|--------------------------------|---------------------------------|-------|---|
| Calendar – Set Date | DD/MM/YY (01/01/00) | | |
| Clock - Set Time | HH:MM:SS (00:00:00) | | <i>When user presses 'ENTER' after editing, seconds are zeroed and clock begins counting.</i> |
| Clock Sync. From Status | Minutes, Seconds | | |

Sub-menu: **Status Config.**

| Setting name | Range (bold = default) | Units | Notes |
|----------------------|--|-------|---|
| Gn Clock Sync | _, 1 for each status input (default: _ _ _ _ _ _ _ _) | | <i>Default - not mapped to any status</i> |

2.2.8 Default Instruments

When a user stops accessing the keypad e.g. on leaving the Sub/Station the relay will, after a user set delay, automatically switch to default metering whereby the user selected default instruments are displayed in turn at 5 seconds intervals without user intervention. The time before this occurs is programmable with the *System Config.:Default Screen Time* setting.

The user can select/deselect the instruments to be displayed in the default metering cycle by going to the *Instrument MODE..* scrolling down to the required default instrument and using the **ENTER** key. This is described in detail in the User Manual document, section 1.3.4.

This function enables the user to set the relay to automatically return to displaying ammeters and other instruments such as ARC Status or Counters. Therefore, essential data is presented to visiting engineers without the need to negotiate the relay's HMI menu structure

Table 2-9 Default Instrument SettingSub-menu: **System Config.**

| Setting name | Range (bold = default) | Units | Notes |
|----------------------------|---------------------------------------|-------|-------|
| Default Screen Time | 10 sec, 60 sec, 5 min , 1 hour | | |

2.2.9 Password

All settings on Argus relays can be password protected. The default password is 'NONE' making the password protection 'not active' therefore all settings can be edited without the relay requesting a password. If a password is set by the user then, before a setting can be changed, the set password must be entered. This allows access for further settings changes to be made without the need to re-enter the password each time. If the user then leaves

the relay keypad untouched for an hour the password protection is re-enabled. The Password setting is changed using the *System Config: Change Password* setting. The user set password is also required to be entered for setting changes or commands performed via the communications link.

Note: if the password is lost/forgotten it can be recovered if the code number shown in the password screen is communicated to Siemens Protection Devices Limited.

Table 2-10 Password Setting

Sub-menu: **System Config.**

| Setting name | Range (bold = default) | Units | Notes |
|------------------------|--|-------|--------------|
| Change Password | ABCDEFGHIJKLMN OP QRSTU VWXYZ1234567890 -+/ (NOT ACTIVE) | | 4 characters |

2.3 Phase-fault and Earth-fault Overcurrent

Argus relays can have up to three phase-fault poles and an earth-fault pole. Each pole has four overcurrent elements which can be used with the starters in blocking and protection schemes.

Phase-fault and earth-fault poles each have a delayed characteristic plus three instantaneous/definite time delay elements. In the directionally controlled Argus 2 and Argus 6 relays each phase-fault and earth-fault delay characteristic, lowset and highset 1 & 2 elements can be independently programmed via their directional control settings to non-directional, forward directional, reverse directional or bi-directional (tri-state) operation via the appropriate directional control setting, e.g. *Protection:P/F Charact. Dir Control* for the phase-fault delay characteristic element.

The operation start of each element can be inhibited from a mapped status input, set via the *STATUS.CONFIG MENU*, to allow comprehensive blocking schemes to be developed. Furthermore, on Argus 2 relays with type II directional elements, the voltage element output can be set to raise inhibits.

The current input signals are sampled at a frequency of 1600 Hz (32 times per 50 Hz cycle) giving a flat frequency response between 47 Hz and 550 Hz, higher harmonics are also included in the r.m.s. calculation. This makes Argus ideal for applications where true RMS accuracy of measurement and timing must be maintained in the presence of high harmonic content in the current waveform e.g. protection of lines carrying variable speed motor loads or for capacitor bank protection.

2.3.1 Delay Characteristic element

The *Protection:P/F Charact. Setting* enables the current level for the delay characteristic starter to be set. The Delay characteristic *Protection:P/F Charact. Setting* can be selected from Inverse Definite Minimum Time (IDMT) characteristic type Normal Inverse (NI) (IEC type A), Very Inverse (VI) (IEC type B), Extremely Inverse (EI) (IEC type C) and Long Time Inverse (LTI), or alternatively a Definite Time Lag (DTL) can be chosen. The time multiplier to be applied to the delay characteristic curve is set using the *Protection:P/F Charact. Time Mult* setting; if DTL has been selected this setting is replaced by the *Protection:P/F Charact. Delay* setting.

Each phase has an independent current-timing element and the algorithms integrate accurately for developing faults where current magnitude in each pole varies with time. Outputs are programmed using the '*O/P Relay Config:P/F Starter*' and '*O/P Relay Config:P/F Charact*' settings for starter pick-up and delayed trip respectively.

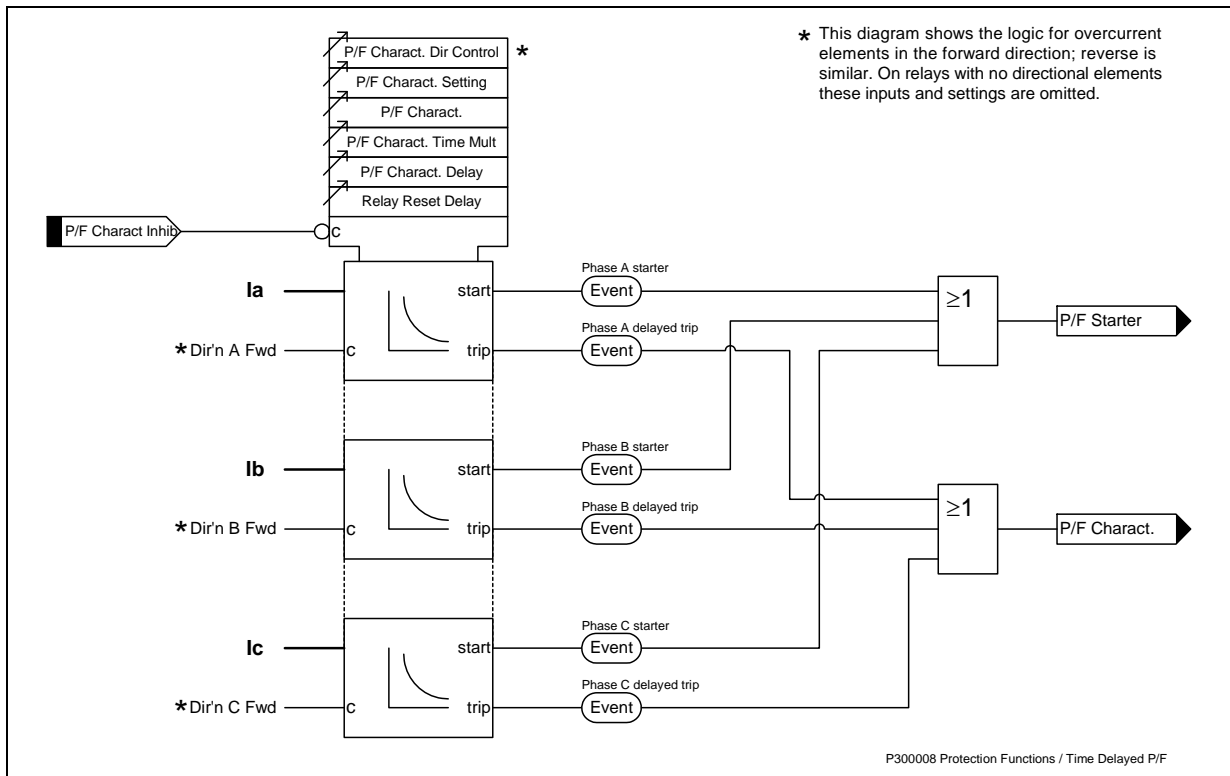

Figure 2.3-1 Functional Diagram – Characteristic Phase-fault Overcurrent Element

The earth-fault pole similarly has its own delayed overcurrent element with its own starter setting and selectable IDMT/DTL characteristic.

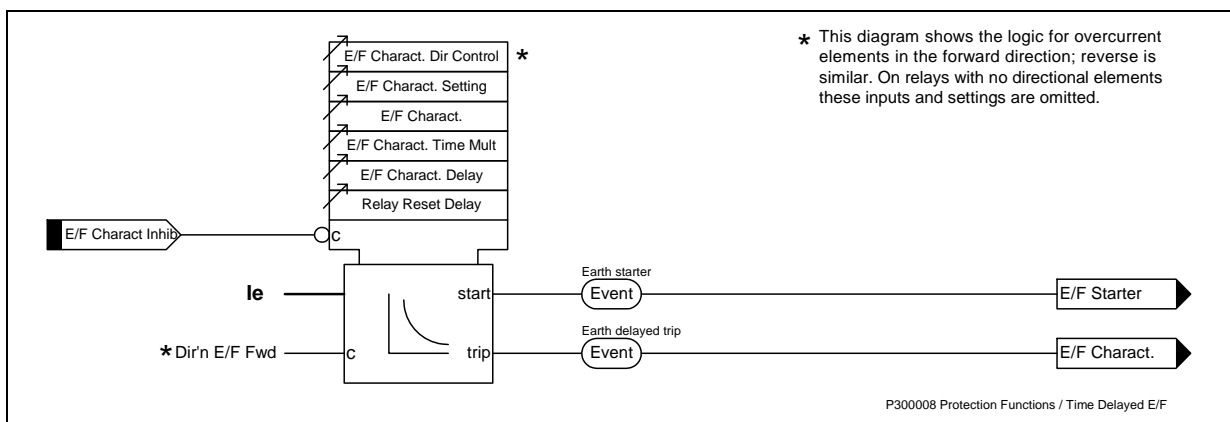

Figure 2.3-2 Functional Diagram – Characteristic Earth-fault Overcurrent Element

2.3.2 Instantaneous elements

There are three separate instantaneous elements per pole: Lowset, Highset 1 and Highset 2. The setting range of each element allows it to be set and used either as a lowset or highset protection, or for overcurrent monitoring. For each element common settings are used by each of the three phase fault poles of the relay, each element has an 'OFF' setting. Each element has a shaped instantaneous characteristic plus follower time delay which can be used to provide time grading margins, sequence co-ordination grading, or for scheme logic. The instantaneous elements have transient free, low overreach, operation under conditions of high values of system X/R.

Figure 2.3-2 and the following text describe the operation of the Lowset element, Highset 1 and Highset 2. Each of these elements is identical in operation.

Each instantaneous element has its own directional control setting *Protection:P/F Lowset Dir Control*. A current level setting *Protection:P/F Lowset Setting* sets the pickup level, which can be followed by a time delay, *Protection:P/F Lowset Delay*, the element output is mapped *O/P Relay Config.:P/F Lowset*.

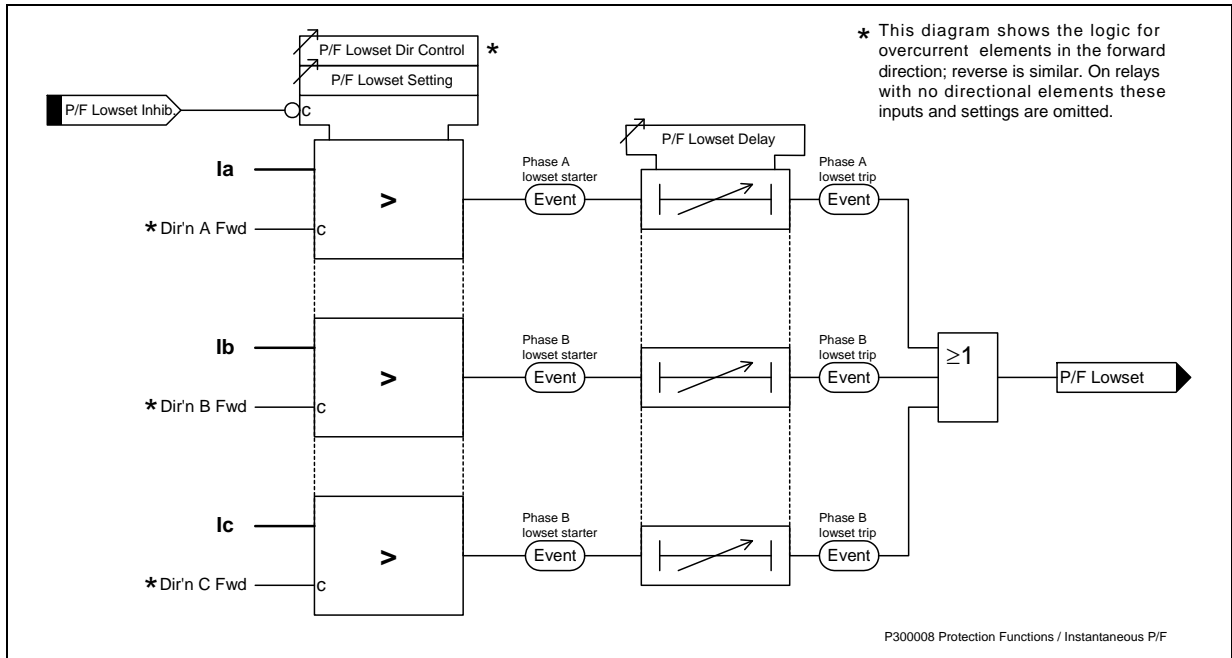

Figure 2.3-3 Functional Diagram – Instantaneous Phase-fault Overcurrent Elements

The earth-fault pole similarly has its own Instantaneous Lowset, Highset1 and Highset2 overcurrent elements with their own starter settings and selectable DTL characteristic.

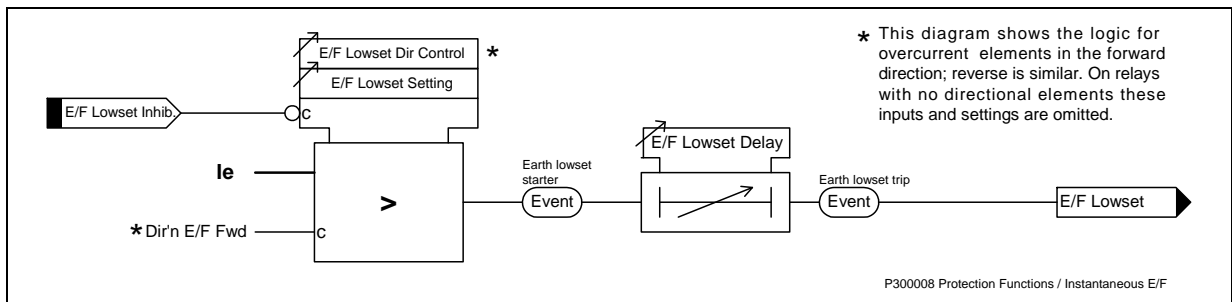

Figure 2.3-4 Functional Diagram – Instantaneous Earth-fault Overcurrent Elements

Table 2-11 Phase-fault and Earth-fault Overcurrent Settings

Sub-menu: **Protection**

| Setting name | Range (bold = default) | Units | Notes |
|---|--|-------|----------------------------------|
| Gn P/F [E/F] Charact. Dir Control | OFF , FWD, REV, TRI | | <i>Argus 2 and Argus 6 only.</i> |
| Gn P/F [E/F] Charact. Setting | 0.05, 0.10, 0.15... 1.00 ...2.50 | xln | |
| Gn P/F [E/F] Charact. | NI , VI, EI, LTI, DTL | | |
| Gn P/F [E/F] Charact. Time Mult | 0.025, 0.050... 1.000 ...1.600 | xt | <i>see note 1 below</i> |
| Gn P/F [E/F] Charact. Delay | 0.00, 0.01... 5.00 ...20.00, 20.5 ...100, 101 ... 300 | sec | |
| Gn P/F [E/F] Lowset Dir Control | OFF , FWD, REV, TRI | | <i>Argus 2 and Argus 6 only.</i> |
| Gn P/F [E/F] Lowset Setting | OFF, 0.05, 0.10... 1.00 ...3.00, 3.5, 4.0...52.5 | xln | <i>see note 1 below</i> |
| Gn P/F [E/F] Lowset Delay | 0.00 , 0.01...20.00, 20.5 ...100, 101 ... 300 | sec | |
| Gn P/F [E/F] Highset 1 Dir Control | OFF , FWD, REV, TRI | | <i>Argus 2 and Argus 6 only.</i> |
| Gn P/F [E/F] Highset 1Setting | OFF, 0.05, 0.10...3.00, 3.5, 4.0... 10.0 ...52.5 | xln | <i>see note 1 below</i> |

| Setting name | Range (bold = default) | Units | Notes |
|---|--|-------|----------------------------------|
| Gn P/F [E/F] Highset 1 Delay | 0.00 , 0.01...20.00, 20.5 ...100, 101 ... 300 | sec | |
| Gn P/F [E/F] Highset 2 Dir Control | OFF , FWD, REV, TRI | | <i>Argus 2 and Argus 6 only.</i> |
| Gn P/F [E/F] Highset 2 Setting | OFF , 0.05, 0.1...3.00, 3.5, 4.0...52.5 | xIn | <i>see note 1 below</i> |
| Gn P/F [E/F] Highset 2 Delay | 0.00 , 0.01...20.00, 20.5 ...100, 101 ... 300 | sec | |

Sub-menu: **O/P Relay Config.**

| Setting name | Range (bold = default) | Units | Notes |
|--|---|-------|-------------------------|
| Gn P/F [E/F] Starter | _, 1 for each output contact (default: _ _ _ _ _) | | <i>see note 1 below</i> |
| Gn P/F [E/F] Charact. Gn P/F [E/F] Lowset Gn P/F [E/F] Highset 1 Gn P/F [E/F] Highset 2 | _, 1 for each output relay R1 – R11 (default: 1 _ _ _ _ _) | | |

Sub-menu: **Status Config.**

| Setting name | Range (bold = default) | Units | Notes |
|--|---|-------|---|
| Gn P/F [E/F] Charact. Inhib. Gn P/F [E/F] Lowset Inhib. Gn P/F [E/F] Highset 1 Inhib. Gn P/F [E/F] Highset 2 Inhib. | _, 1 for each status input S1 – S11 and Vstart (default: _ _ _ _ _) | | <i>Argus 2 type II relays only, each element can be set to be inhibited from the voltage element starter.</i> |

Note 1. If the directional control is set to tri-state, these settings will be duplicated for forward and reverse directions. The settings for the forward direction are indicated by an 'F' following the group number (e.g. GnF P/F Charact.), while the settings for the reverse direction are indicated by an 'R' (e.g. GnR P/F Charact.).

Note 2. The above table shows the settings for phase-fault elements, with the text for earth-fault indicated by square brackets, e.g. Protection:Gn P/F Charact. Dir Control becomes Protection:Gn E/F Charact. Dir Control.

2.3.3 Flashing (Pecking) Fault Protection

Flashing Faults are characterised by a series of short pulses of fault current which are intermittent, if the IDMT/DTL element characteristic has an instantaneous reset then it may not operate. In order to detect and operate for such faults the relay has a setting that enables the user to set the Protection:Relay Reset Delay. This setting modifies the reset-mode of the IDMT/DTL protection algorithm such that after the fault current has disappeared the current time totals are held. For faults that re-appear within the Relay Reset Delay time the current-time integration continues from the last value reached. Where the fault current does not reappear within the Relay Reset Delay time then the integrator will reset to zero and any subsequent fault will start a new integration of current-time. Thus for flashing faults where the fault current pulses reappear within the set reset time, up to 60 seconds after the end of the last pulse, the delayed characteristic will operate on the summation of the fault current-time.

Where auto-reclose is not required after a delay protection trip i.e. sequence = 2I + 1D, then the Relay Reset-Delay time setting should be set to 60sec. Where a delay protection trip is to be followed by auto-reclose + delay protection then this setting may be left at the default value of instantaneous or set to a time which is less than the reclose delay between consecutive delay protection operations. Setting times as above will provide flashing fault coverage and still allow grading between relays in series on the system.

If this function is not required the Relay Reset Delay time can be set to 'INST'.

Table 2-12 Flashing Fault Setting

Sub-menu: **Protection**

| Setting name | Range (bold = default) | Units | Notes |
|-----------------------------|---------------------------------|-------|-------|
| Gn Relay Reset Delay | INST , 1,2...60 | sec | |

2.4 Sensitive Earth-fault and Restricted Earth-fault

This element can be used for either sensitive earth-fault or high-impedance restricted earth-fault protection schemes. The two applications are not possible simultaneously – the user must select which is required. The restricted earth-fault scheme is described in section 2.4.1 below.

The element includes a software filter for rejection of second, third and higher harmonics of the power system frequency. The instantaneous element, set using *Protection:SEF/REF Current Setting*, provides a starter output. Two sequential DTL follower timers (*Protection:SEF/REF 1st Time Delay* and *Protection:SEF/REF 2nd Time Delay*) plus an additional timer (*Protection:SEF/REF Lowset Delay*) are provided; all use the same *Protection:SEF/REF Current Setting*. The delayed reset function (section 2.3.3) is applied on each of the two DTL timers.

Each of the three timing elements has an output, mapped by a setting. Each timing element can be inhibited from a status input, mapped by a setting, see Figure 2.4-1.

In multi-pole directional Argus models the SEF element is non-directional. In single-pole directional SEF models the directional control setting applies to all the SEF Protection elements.

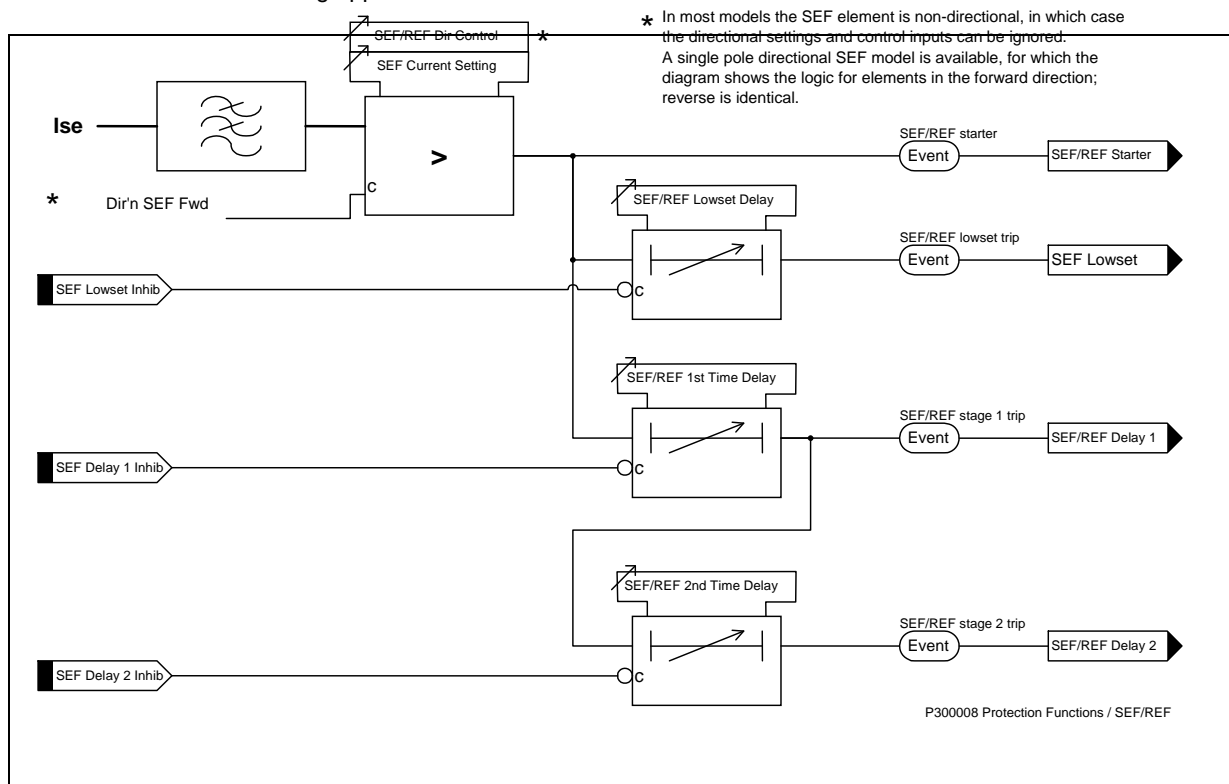

Figure 2.4-1 Functional Diagram – Sensitive Earth-fault/Restricted Earth-fault Elements

Table 2-13 Sensitive Earth-fault / Restricted Earth-fault Settings

Sub-menu: **Protection**

| Setting name | Range (bold = default) | Units | Notes |
|----------------------------|---|-------|--------------------------------------|
| Gn SEF Dir Control | OFF , FWD, REV, TRI | | Argus 2 Single-pole dir'n. SEF only. |
| Gn SEF/REF Current Setting | 0.005, 0.010... 0.050 ...0.960 | xIn | see note 1 below |
| Gn SEF/REF 1st Time Delay | 0.00, 0.01... 5.00 ...20.00, 20.5 ...100, 101 ... 300 s | sec | |
| Gn SEF/REF 2nd Time Delay | OFF, 0.00, 0.01... 5.00 ...20.00, 20.5 ...100, 101 ... 300 s | sec | |
| Gn SEF/REF Lowset Delay | 0.00 , 0.01...20.00, 20.5 ...100, 101 ... 300 s | sec | |

Sub-menu: **O/P Relay Config.**

| Setting name | Range (bold = default) | Units | Notes – see note 1 below |
|--------------|---------------------------------|-------|--------------------------|
| | | | |

| Setting name | Range (bold = default) | Units | Notes – see note 1 below |
|--|--|-------|--|
| Gn SEF/REF Starter | _, 1 for each output contact (default: _____) | | |
| Gn SEF/REF Delay 1 Gn SEF/REF Delay 2 Gn SEF/REF Lowset GnF SEF/REF Block GnR SEF/REF Block | _, 1 for each output contact (default: _ 1 _____) | | see note 1 below default settings – all Protection elements energise the Trip output relay 2. |

Sub-menu: **Status Config.**

| Setting name | Range (bold = default) | Units | Notes |
|---|---|-------|-------|
| Gn SEF/REF Delay 1 Inhib. Gn SEF/REF Delay 2 Inhib. Gn SEF/REF Lowset Inhib. | _, 1 for each status input (default: _____) | | |

Note 1. On the single-pole directional SEF model, if the directional control is set to tri-state these settings will be duplicated for forward and reverse directions. The settings for the forward direction are indicated by an 'F' following the group number (e.g. *GnF SEF Current Setting*), while the settings for the reverse direction are indicated by an 'R' (e.g. *GnR SEF Current Setting*).

2.4.1 High Impedance Restricted Earth-fault Scheme

Externally mounted power resistors, connected in series with the relay, are required to set the stability voltage V_S . See Section 3: Application Notes for the theory and formulae required to calculate the I_S and V_S settings and resistor values. A non-linear resistor may also be required to protect the scheme wiring and current transformers against transient over-voltages at high fault levels.

2.5 Primary Equipment Fail Protection

2.5.1 Circuit Breaker (Trip) Fail Protection

Provides 50CBF Trip Fail two-stage time delay with Phase, Earth and SEF current level detectors.

If the Circuit Breaker (CB) fails to respond to a Trip output and fault current continues to flow, then the ARGUS Circuit Breaker Fail (CBF) function can be set to automatically issue a graded, time-delayed, CBF 1 output (Re-trip) then, if that fails, a second CBF 2 output (Back Trip to an up-stream CB).

Any Protection element or Status input for which a Trip output is required must be mapped to an output relay which in turn is mapped to 'Fault Trigger'. When 'Fault Trigger' is raised this enables the CBF current level detectors that check for cessation of current flow in each pole. If and while any current exceeds setting, specified by *Protection:P/F CB Fail Setting*, *Protection:E/F CB Fail Setting* or *Protection:SEF CB Fail Setting*, then CBF Time delay 1 timer, specified by *Protection:CB Fail Time Delay 1*, runs. On time-out the CB Fail 1 output is raised, this can be mapped to another output relay to provide a re-trip output.

A second CBF timer, specified by *Protection:CB Fail Time Delay 2*, then starts and runs if and while current exceeds setting. On time-out CB Fail 2 output is raised, this can be mapped to a different output relay to provide a Back-trip output.

NB:- If CBF is to be applied then a current setting should be entered for all poles i.e. P/F & E/F & SEF settings. Typical settings will be below the protection settings applicable for each pole; phase fault setting can normally be above maximum Load current. The CBF scheme will then run until all currents fall below the set detector levels. If any CBF current setting is set to OFF i.e. Zero current, then, once enabled, the CBF function will run until all currents are zero. Grading time margins and settings will be typically 200ms for CB Fail Time delay 1, and 200ms for CB Fail Time delay 2.

If CBF is not required then CBF Time delay 1 and CBF Time delay 2 should be set to OFF i.e. Infinity.

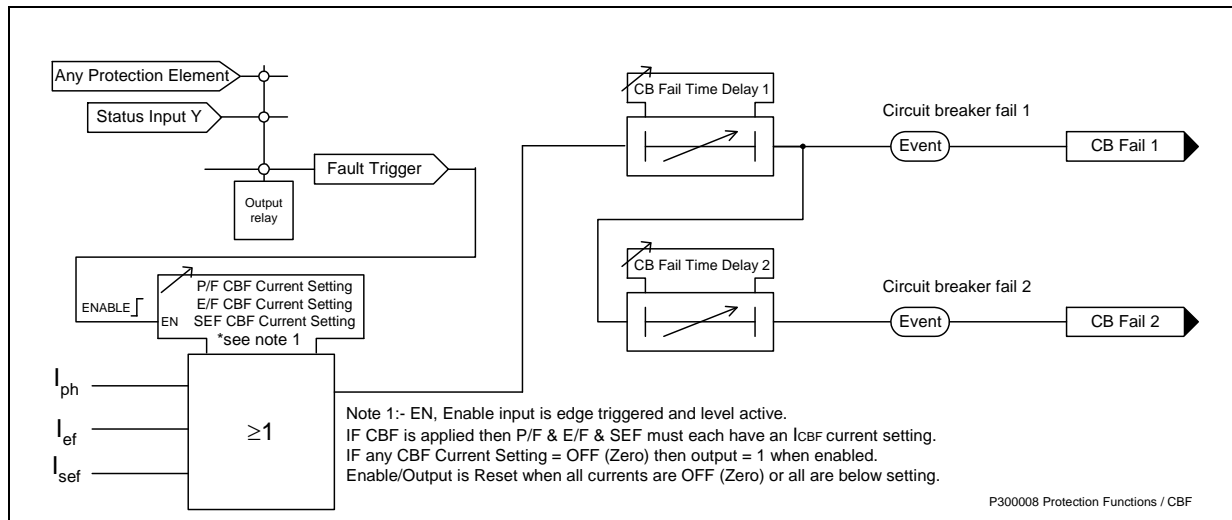

Figure 2.5-1 Functional Diagram – Circuit Breaker Fail

Table 2-14 Circuit Breaker Fail Settings

Sub-menu: **Protection**

| Setting name | Range (bold = default) | Units | Notes |
|-------------------------|---------------------------------------|-------|-------|
| Gn P/F CB Fail Setting | OFF , 0.05, 0.1 ... 1.00 | xIn | |
| Gn E/F CB Fail Setting | OFF , 0.05, 0.1 ... 1.00 | xIn | |
| Gn SEF CB Fail Setting | OFF , 0.005 ... 0.96 | xIn | |
| Gn CB Fail Time Delay 1 | OFF , 0.00, 0.01...20.00, 20.5 | sec | |
| Gn CB Fail Time Delay 2 | ...100, 101 ... 300 s | | |

Sub-menu: **O/P Relay Config.**

| Setting name | Range (bold = default) | Units | Notes |
|--------------|--------------------------------------|-------|-------|
| Gn CB Fail 1 | _ , 1 for each output contact | | |
| Gn CB Fail 2 | (default: _ _ _ _ _) | | |

2.5.2 Close Fail

Argus 4 and Argus 6 only

Circuit breaker close operation is also monitored. The relay checks the status of the CB at the end of each close pulse. If the CB has not closed then the relay locks out due to CB close fail, and any sequence is terminated.

2.5.3 Current Transformer Failure

The current flowing from each of the Phase Current Transformers is monitored. If one or two of the three input currents falls below the CT Supervision current setting for more than the CT Failure time delay then CT Failure is raised. If all three input currents fall below the setting CT Failure is not raised.

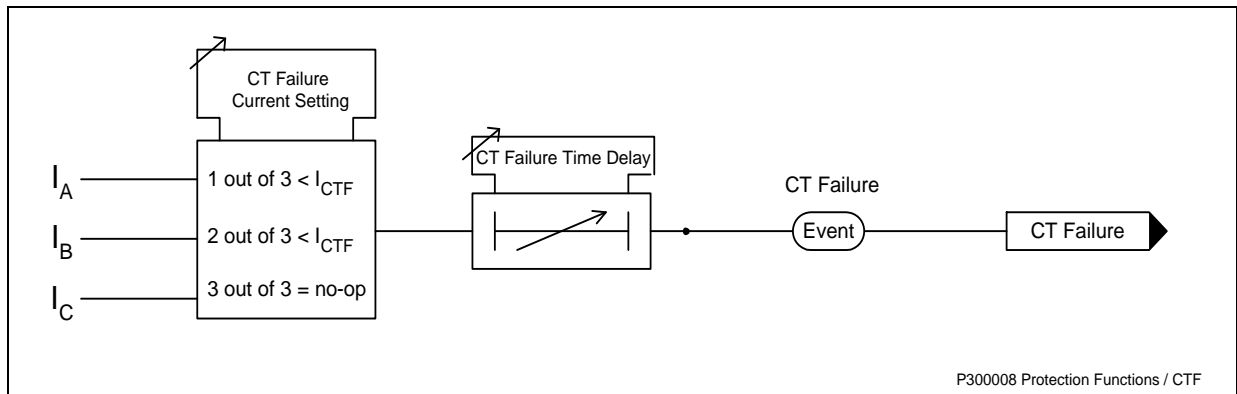

Figure 2.5-2 Functional Diagram – Current Transformer Fail

Table 2-15 Current Transformer Fail Settings

Sub-menu: **Protection**

| Setting name | Range (bold = default) | Units | Notes |
|------------------------------|---|-------|-------|
| Gn CT Failure Setting | OFF , 0.05, 0.1 ... 1.00 | xIn | |
| Gn CT Failure Delay | OFF , 0.00, 0.01...20.00, 20.5 ...100, 101 ... 300 s | sec | |

Sub-menu: **O/P Relay Config.**

| Setting name | Range (bold = default) | Units | Notes |
|----------------------|---|-------|-------|
| Gn CT Failure | _ , 1 for each output contact (default: _____) | | |

2.5.4 Trip Circuit Supervision - for details see sections 2.10 and 3.8

2.6 Cold Load Protection

Argus 4 and Argus 6 only

A cold load protection function is provided to cater for closing onto the type of load that, after being de-energised for some time, on energisation takes a high level of current for an extended period.

The *System Config: Cold Load Pickup Group* setting allows the user to select the setting group number to which the relay will switch after the circuit breaker has been open for longer than the user-set *Auto-reclose: Cold Load Enable* time. This cold load group's overcurrent settings will normally be set higher and the time characteristics will be set slower than the normally-active group's settings. The relay will switch to the nominated cold load group n and then when the circuit breaker is closed will apply that group's overcurrent and auto-reclose settings until the user-set *Autoreclose: Cold Load Reset* time expires, then revert to the normally-active group.

The Relay can be set up to revert to the normally active group sooner if the load current falls and remains below the cold load group's *Protection: P/F Highset 2 Setting* for longer than the *Protection: P/F Highset 2 Delay* timer. Phase-fault highset 2 in the set cold load group operates as an under-current element. This element's setting should be set, 5% or more, below the normally-active group's phase-fault overcurrent element settings. This prevents the relay from changing back, from the cold load group to the normally active group, before the cold load inrush current has fallen below the normally active group's P/F starter settings, so that when the relay reverts to the normally-active group settings the relay does not then operate and give a trip output. The cold load group's phase-fault highset 2 element will be picked up during cold load inrush conditions and should not be user mapped to the trip relay.

Selecting the cold load group's Phase Fault highset 2 to OFF will de-select this fast revert mode, reversion will then only occur at the end of the cold load reset delay.

At the end of the cold load reset delay, if the current is still above the HS2 setting, or any starter is picked up, the relay will issue a trip and lockout. It will then revert to the normally-active group settings.

Automatic cold load pick-up can be disabled by setting the *Auto-reclose: Cold Load Enable* time delay to OFF. This still allows Cold Load Group n to be selected via a mapped Status Input.

Table 2-16 Cold Load Pickup SettingsSub-menu: **System Config.**

| Setting name | Range (bold = default) | Units | Notes |
|-------------------------------|---------------------------------|-------|-------|
| Cold Load Pickup Group | 1,2... 8 | | |

Sub-menu: **Auto-reclose**

| Setting name | Range (bold = default) | Units | Notes |
|-------------------------|---|-------|-------|
| Cold Load Enable | OFF , 0.20...2.0, 2.1...20, 21...300, 360...3600, 3900...14400 | sec | |
| Cold Load Reset | 0.20...2.0, 2.1...20, 21...300, 360... 600 ...3600, 3900...14400 | sec | |

2.7 Directional Control

Argus 2 and Argus 6 only

Each phase-fault and earth-fault delay characteristic, lowset and highset elements can be independently programmed to non-directional, forward directional, reverse directional or bi-directional (tri-state) operation. The SEF/REF element on most Argus 2 and Argus 6 models is not normally directional, however, a single-pole directional SEF model is available.

Figure 1.5-7 illustrates the directional operating characteristic relative to the characteristic angle (CA), historically known as the maximum torque angle. This is the phase angle of the fault current relative to the polarising voltage reference for which the directional detector gives maximum sensitivity in the forward operate zone. The reverse operate zone is an exact mirror image of the forward zone. The directional element is referred to as 'tri-state' because conditions will occur for which neither the forward nor the reverse element should operate.

If a protection element is programmed by the user to be non-directional then only non-directional overcurrent settings will be presented. The element will operate independently of the output of the directional detector and operation will occur for current above setting regardless of phase angle.

If a protection element is programmed for forward directional mode then the forward zone overcurrent settings will be presented and operation will only occur for fault current falling within the forward operate zone. Conversely, if a protection element is programmed for reverse directional mode then the reverse zone overcurrent settings will be presented and operation will only occur for fault current falling within the reverse operate zone.

Where the tri-state option is selected an element will operate for fault current above its setting in either direction. Different overcurrent settings can be programmed for forward and reverse operation. In addition, the forward and reverse trip output signals can be issued to different output contacts.

Directional relays can be applied to directional blocking schemes. Both phase and/or earth fault blocking outputs can be generated for forward or for reverse direction faults, e.g. *Protection:P/F FWD Block* specifies relays which will operate for a phase-fault in the forward direction.

Blocking inputs can be received via the status inputs, each of which can be programmed to inhibit operation of any overcurrent protection element - see section 2.2.

2.7.1 Polarisation

Phase-fault

Voltage polarisation is achieved for the phase-fault elements using the quadrature voltage whereby each phase current is compared to the voltage between the other two phases, i.e.

$$I_A \sim V_{BC} \quad I_B \sim V_{CA} \quad I_C \sim V_{AB}$$

Two types of directional element exist, referred to here as type I and type II. On a relay with type I directional elements the phase-fault characteristic angles can be user programmed to either +30° or +45° using the *Protection:P/F Charact Angle* setting. On a relay with type II elements, any characteristic angle between -90° and +90° can be selected. The characteristic angle setting should be matched to the approximate expected nominal angle of system fault, i.e. the source impedance angle.

Earth-fault

Voltage polarisation is also used for earth fault elements, comparing the earth fault current I_e ($3I_0$) against the system residual voltage V_n ($3V_0$).

In relays with type I directional elements the residual voltage is obtained from the open delta connection of the tertiary windings of the line-N voltage transformers. The earth-fault characteristic angles can be user programmed to **0°, -15°, -45° or -65°** using the Protection:E/F Charact Angle setting.

In relays with type II directional elements an open delta tertiary winding can be used or alternatively the relay will itself calculate the residual voltage internally from the three applied phase-earth voltages. With these relays any characteristic angle between -90° and +90° can be selected. The characteristic angle setting should be matched to the expected nominal angle of system fault.

Note that when type I directional Argus relays are used on 60Hz systems the nominal characteristic angles will change slightly, typically P/F by less than +5° and E/F by less than -5°.

2.7.2 Two-out-of-three Gate

This feature is applicable to relays with three directional phase-fault poles. It provides the means of achieving absolute discrimination, between two directional overcurrent protection relays, in power system applications where +1 : -2 : +1 fault current distribution can occur.

When the Directional:2-Out-Of-3 Gate Logic setting is set to ON, the directional elements will only operate for the majority direction, e.g. if phase A and C detect forward current flow and phase B detects reverse current flow, phase A and C will operate forwards, while phase B will be inhibited.

2.7.3 Voltage Memory

In the condition of a 3 phase fault where the polarising voltage collapses the relay can maintain the Forward or Reverse direction for each pole for up to 0.5 s. The Directional:Voltage Memory setting is used to set the amount of time the relay will hold the memory of the direction.

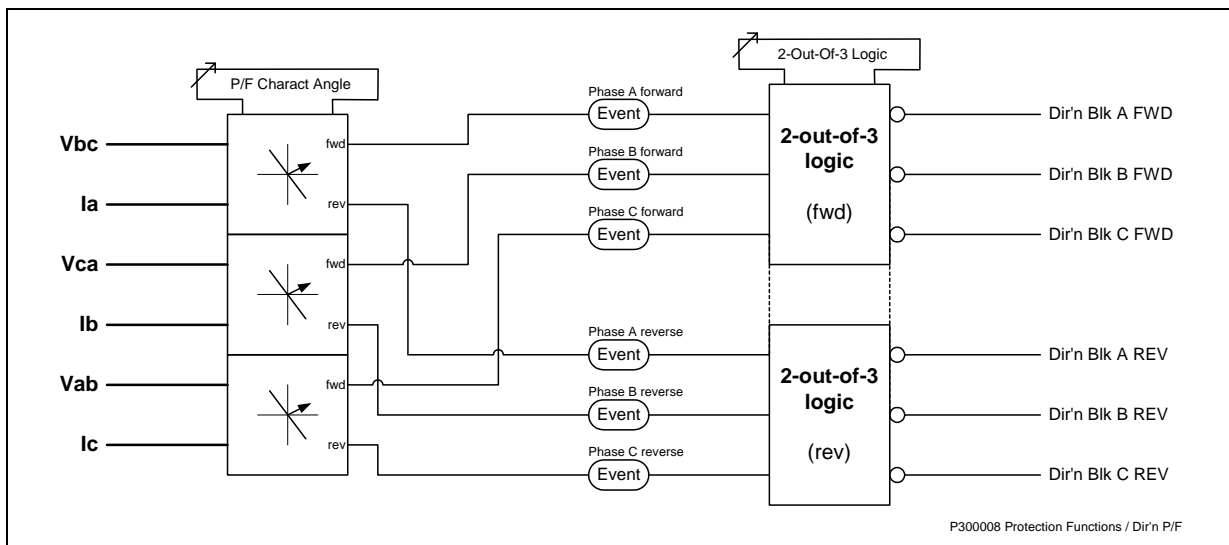

Figure 2.7-1 Functional Diagram – Phase-fault Directional Element

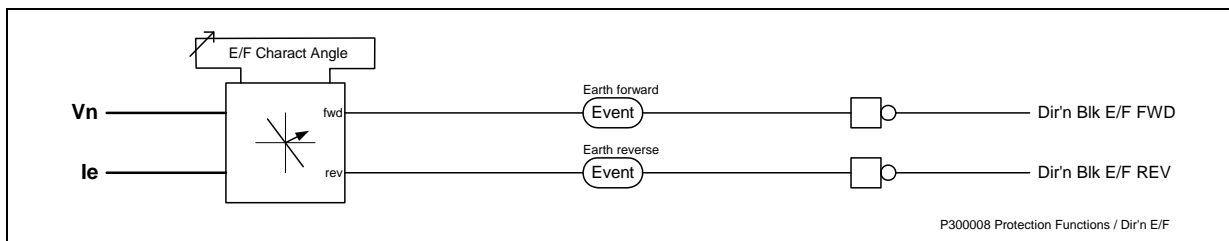

Figure 2.7-2 Functional Diagram – Earth-fault Directional Element

Table 2-17 Directional Settings

Sub-menu: **Directional**

| Setting name | Range (bold = default) | Units | Notes |
|--------------|---------------------------------|-------|-------|
|--------------|---------------------------------|-------|-------|

| Setting name | Range (bold = default) | Units | Notes |
|------------------------------|---------------------------------|-------|------------------|
| 2-Out-Of-3 Gate Logic | OFF , ON | | |
| P/F Charact Angle | +30, +45 | ° | Type I element. |
| | -90, -89... +45 ...+90 | ° | Type II element. |
| E/F Charact Angle | 0, -15 , -45, -65 | ° | Type I element. |
| | -90, -89... -15 ...+90 | ° | Type II element. |
| SEF Charact Angle | 0, -15 , -45, -65 | ° | Type 1 only |
| Voltage Memory | OFF, 0.1 ... 0.5 | sec | |

Sub-menu: **O/P Relay Config.**

| Setting name | Range (bold = default) | Units | Notes |
|--|--|-------|---|
| Gn P/F FWD Block Gn P/F REV Block Gn E/F FWD Block Gn E/F REV Block | _, 1 for each output contact (default: _____) | | |
| Gn SEF FWD Block Gn SEF REV Block | _, 1 for each output contact (default: _____) | | Argus 2 single-pole directional SEF only. |

2.8 Voltage Protection

Argus 2 (type II) models only

A single three-phase voltage element with definite time delay is provided. The *Voltage:V.Operation* setting allows the element to be set for overvoltage or undervoltage operation. When set to undervoltage an additional blocking threshold (*Voltage:V.Block.Threshold*) prevents inadvertent operation when the system is de-energised.

An instantaneous output is driven from the level detector (*Voltage:V.Ph-Ph.Setting*)/(*Voltage:V.Ph-N.Setting*), with a follower definite time delay *Voltage:V.Delay* driving the *Voltage:V.Trip* output. These outputs can be set by the *Voltage:V.O/P.Phases* setting to operate from any phase operation, or only when all phase elements operate.

The *Voltage:V.Hysteresis* setting specifies the percentage above or beneath the (*Voltage:V.Ph-Ph.Setting*)/(*Voltage:V.Ph-N.Setting*), setting at which the element resets. For example, an element with *Voltage:V.Operation* set to Overvoltage, *Voltage:V.Setting* of 100 V and *Voltage:V.Hysteresis* of 1 % will nominally operate above 100 V and reset below 99 V. If *Voltage:V.Operation* is set to Undervoltage, the element will operate below 100 V and reset above 101 V.

The voltage elements are set in terms of the directly measured voltage. If used for phase-phase connection the voltage elements will be phase-phase; if used for phase-neutral connection the voltage elements will be phase-neutral.

The voltage elements provide pole-by-pole outputs that can be used to block the appropriate overcurrent element using the *Status.Config:P/F.xxxx.Inhibit* settings. Note that if used with phase-phase connection of the voltage inputs, the Vab element will block the phase A overcurrent element, Vbc will block phase B overcurrent and Vca will block phase C overcurrent.

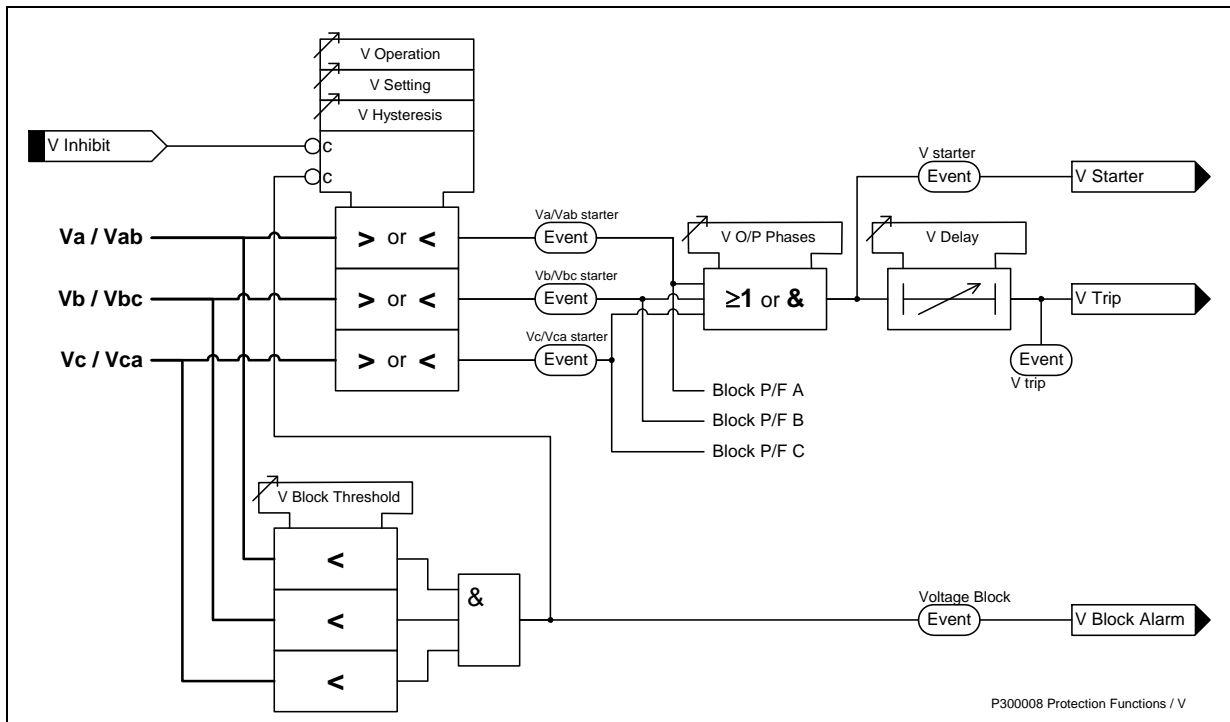

Figure 2.8-1 Functional Diagram – Undervoltage/Overvoltage Element

Table 2-18 Voltage Protection Settings

Sub-menu: **Voltage**

| Setting name | Range (bold = default) | Units | Notes |
|---|--|-------|---|
| Gn V Operation | OFF , O/V, U/V | | |
| Gn V Setting (Ph-N) Gn V Setting (Ph-Ph) | 5.0, 5.5... 80.0 ...200.0 | V | Setting indicates whether phase-phase or phase-neutral is in use – set by <i>System Config.:VT.Connection</i> |
| Gn V Delay | 0.00 , 0.01...20,20.5... 100.0,101.0...600.0 | sec | |
| Gn V Hysteresis | 1, 2 ...90 | % | |
| Gn V Block Threshold | OFF,1,2... 5 ...100 | V | |
| Gn V O/P Phases | Any One , All | | |

Sub-menu: **O/P Relay Config.**

| Setting name | Range (bold = default) | Units | Notes |
|--|--|-------|-------|
| Gn V Starter Gn V Trip Gn V Block Alarm | _, 1 for each output contact (default: _____) | | |

Sub-menu: **Status Config.**

| Setting name | Range (bold = default) | Units | Notes |
|---------------------|--|-------|-------|
| Gn V Inhibit | _, 1 for each status input (default: _____) | | |

2.9 Auto-Reclose

Argus 4 and Argus 6 only.

Approximately 90% of all overhead line faults are transient (non-damage) arcing Phase(s) to Earth faults induced by lightning or due to other transient initiation. Use of a sequence of Instantaneous (Lowset) trips followed by Delayed trips e.g. 2I + 1D with line Dead-Times (Reclose Delays) ensures that such transient faults are cleared quickly before consequential permanent damage to the plant can occur and hence, after the line has been dead for a short time (1 – 5 s) to allow arc by-products and ionised air to disperse, the healthy line can be reclosed and

the system restored. The Delay trips ensure that, if the instantaneous trips do not clear the fault i.e. it is permanent, grading of the protections in series on the system occurs and the protection closest to the fault will trip and isolate the fault.

2.9.1 Auto Reclose Sequences

The AUTO_RECLOUSE_MENU enables the user to programme independent auto-reclose sequences for phase-fault, earth-fault, sensitive earth-fault, and/or auto-reclose initiation from an external protection trip via a status input mapped to STATUS_CONFIG:ARC_Status_A (SA). For each sequence the user can select the optimum sequence settings i.e. each trip can be selected to be either INSTantaneous or DELAYed with different Dead Times before Reclosure for each shot. The User can set the required Sequence and number of Instantaneous trips and Delayed trips to LockOut, the number of shots (Recloses) to LockOut, the number of High Set 1 Instantaneous trips to LockOut and the number of High Set 2 trips to LockOut, allowed to achieve maximum retention/availability of the power system. After each trip the relay determines its next course of action using the User settings. The correct Auto-Reclose delay and Protection Characteristic response is applied after each trip in response to the type of fault cleared, thus the correct sequence is applied at each stage of a developing fault.

Note:- in the AUTO_RECLOUSE:P/F_Protection_Trip settings, INST refers to Instantaneous LowSet and not to instantaneous HighSet. Also all protection elements operate in parallel, therefore, the first non-inhibited element, that is mapped to trip, to time out will generate a trip output. The Delay and HighSet elements 1 & 2 can be used together to provide a composite characteristic with IDMTL/DTL operation at low fault levels and higher speed operation at higher fault levels to grade with fuses etc.

Sequence Co-ordination of the Instantaneous (Lowset) and Delayed protection operation of two relays in series on a feeder is automatically provided if the upstream Lowset Instantaneous has a grading delay set. Grading between both relays' Lowsets will be maintained and both upstream and downstream protections will keep their shot counters in-step throughout a sequence; the upstream protection will apply the same sequence of INST/DELAY protection, grading with the downstream CB on each shot and not tripping, thus the downstream CB performs all the necessary trips to clear the fault.

To monitor the Circuit Breaker position the relay uses two Status inputs, mapped to the STATUS_CONFIG:CB_Open and STATUS_CONFIG:CB_Closed settings, and Fault current monitoring to determine if the circuit breaker is open or closed. If the CB is closed, or its state indeterminate due to interlock failure producing conflicting inputs, a reclose Close pulse output will be inhibited, but a Manual Close & Reclaim or Remote Close & Reclaim Close pulse output is always allowed.

The AUTO_RECLOUSE:P/F_ARC, AUTO_RECLOUSE:E/F_ARC, AUTO_RECLOUSE:SEF_ARC and AUTO_RECLOUSE:SA_ARC - IN/OUT settings enable auto-reclose to be independently selected ON or OFF for each fault type. When ARC is set to IN (On) i.e. switched into service, each setting can be overridden to OUT (Off) via a raised mapped status input STATUS_CONFIG:P/F_ARC Off etc., or by being set to Off via the communications link commands. Overall All ARC On/Off may also be set via the Relay's Linesman Mode:ARC ON/OFF setting (see section 2.14.2) or via a communications link AutoReclose OFF command.

At significant stage points during an auto reclose sequence the relay logs and sends named events via the communications link, with raised or cleared status as applicable. These named events greatly assist the user in the process of determining the timing and exact sequence of events and the relay's response to system fault conditions. The relay also indicates the status and progress of the auto reclose sequence via its ARC Status and ARC Inhibits Instruments.

2.9.1.1 Protection and Auto Reclose Sequences

The following clauses describe the functionality of each setting in the Auto Reclose Menu for the Phase Fault sequence. Identical settings and comments apply to the Earth Fault, Sensitive Earth Fault, and External Arc Start via Status ARC start (SA) sequences. Each Settings Group G1, G2...G8 can have different Auto Reclose sequence settings, or none, applied by the User.

Gn Line Check Trip = ON/OFF

The Auto-reclose:Line Check Trip setting allows this function to be enabled (ON) or dis-enabled (OFF) and is applied to all Groups (G1 to G8) and all Sequences i.e. P/F, E/F, SEF & SA.

With Auto-reclose:Line Check Trip = ON, if the circuit breaker is closed via a Close pulse from the relay in response to a raised 'Local Close & Reclaim' or a 'Remote Close & Reclaim' command raised via a mapped status input, or communications command, or from the Linesman menu Linesman Mode:Close & Reclaim (section 2.14.2); then the Line Check Trip (switch on to fault) function is activated and remains activated until the Reclaim Timer resets.

The Line Check function ensures that if the circuit breaker is closed onto a permanent fault, or if the circuit breaker closes onto a healthy line but a fault then develops within the Auto-reclose:Reclaim Time setting, that the relay will perform only one trip to Lockout, The relay will trip but it will not reclose nor go through an auto reclose sequence.

The protection applied for Line Check Trip can be set independently for P/F, E/F, SEF/REF and/or SA, to either INST (Instantaneous Lowset) or to DELAYED (Delayed + HS1 + HS2), by the relevant *Auto-reclose:Line CheckTrip* settings.

An example of this setting's use is that after a lockout state is reached the user can set Line Check Trip to OFF so that when the Circuit Breaker is then manually closed onto a permanent fault the relay is forced to go through an auto reclosing sequence to ensure that sectionalising/grading occurs to isolate a permanently faulted section of the system. After successful isolation *Auto-reclose:Line Check Trip* should be set back to ON.

P/F ARC = IN/OUT

Auto-reclose:P/F ARC setting,

If set to IN (on) the relay will perform a full Phase Fault AutoReclose sequence,

If set to OUT (off) the relay will perform a one Trip to Lockout sequence applying the first programmed protection trip characteristic unless this is overridden by any applied inhibit controls.

The first protection trip characteristic in a sequence will typically be set to INST i.e. Instantaneous Lowset, therefore, if *P/F ARC* is set to OUT (off) the relay will not grade with other Protections in the system to isolate a permanent fault. However, the relay can be re-configured to perform one delayed Trip to Lockout by raising *P/F Lowset Inhib.*, preventing the Instantaneous Lowset from operating, thus allowing the IDMT Characteristic etc. to grade.

P/F Lowset can be Inhibited by a raised status input mapped in *Status Config:P/F Lowset Inhib.*, or *P/F INST ON/OFF* can be set via the communications link commands. All *Inst. Lowset ON/OFF* may also be set via the relay's *Linesman Mode:Inst. Lowset ON/OFF* setting (see section 2.15) or via a communications link *P/F Instantaneous ON/OFF* command.

Protection Trips 1 to 4

The Protection characteristic applied for each of the first four trips in a sequence can be user set to INST Instantaneous (LowSet) or composite delayed + HighSet1 + HighSet2 characteristic, as specified by the *Auto-reclose:P/F Protection Trip 1(2)(3)(4)* settings. Any combination of inst (I) & Delayed (D) trips is allowed e.g. 2I + 2D, or I+D+I+D, or 2D + 2I etc.. However, the fifth trip in any sequence, if allowed by the user, will always apply the composite delayed + HS1 + HS2 characteristic to attempt to retain as much of the system in service as possible.

The two highset elements can be applied as trip elements with the delayed characteristic to provide a composite characteristic, or used as independent elements. The *Auto-reclose:P/F HS1 Trips To Lockout* and *Auto-reclose:P/F HS2 Trips To Lockout* settings may be set to limit the number of high current trips, or, if set to 1 to truncate a P/F sequence to Lockout if the HS1 or HS2 fault level setting is exceeded.

Reclose Delay (Dead time) and Close Routine

The Reclose delay or line Dead Time, is basically the length of time the Circuit Breaker is open before being reclosed. An auto reclose sequence may have more than one Reclose delay.

After the first and subsequent trips, when the Circuit Breaker has opened and all starters and External ARC Start SA are cleared, the relay checks the reason for that Trip and determines its next state.

If the relay determines that it is not to go to Lockout but is to proceed to perform the next set step in the Auto-Reclose sequence, the relay applies the Reclose Delay (dead time) specified by the *Auto-reclose:P/F Reclose DTL [1][2][3][4]* settings, the Auto Reclose sequence commences and an 'Arc Active' event and alarm is raised, this may be mapped by the user to an output relay as defined by the *O/P Relay Config:ARC Active* setting. The output remains raised until the sequence has successfully reclaimed, or a lockout occurs, at which time the 'Arc Active' event and alarm output is cleared.

After the Reclose Delay the relay enters the Reclose routine and checks that Reclose Block is not raised before issuing a close pulse via the output relay output contacts specified by the *O/P Relay Config:Close Pulse* setting. Note: If any ARC INHIBIT is raised before or at any time during a Reclose Delay or during the Reclose Block time the relay will go to Lockout.

A raised status input mapped to *Status Config:Reclose Block* can be used to prevent autoreclosing if external conditions do not allow an immediate close of the circuit breaker e.g. if a motor wound circuit breaker close spring needs additional time to recharge or if the system is out of synchronism, etc. External blocking contacts can be wired in parallel. If all the reclose block inputs are not cleared within the 5 second reclose-block time delay the relay will go to Lockout. If all the reclose block inputs are cleared at any time within the 5 secs reclose-block time delay then the close pulse will be issued, thus the autoreclose close pulse may be held back by up to 5 secs after the end of the reclose delay.

The Close Pulse duration is set using the *Auto-reclose:Close Pulse* setting. The close pulse will be truncated either when the *Status Config:CB Open* and *Status Config:CB Closed* status inputs show that the CB has closed, or if the CB closes onto a fault and any protection starter picks up. Thus the close pulse may be left set to the default of 2 seconds without racing conflicts being created. The relay will not issue a Close pulse to a closed CB.

The relay also provides an Auxiliary Close output that can be mapped to an output relay by *O/P Relay Config.:AUX Close* which will be energised for 200 ms before the end of the close pulse. This output can be used to energise an external relay with a heavy duty break contact, connected in series with the close coil of the CB, to prevent output contact damage for a stuck circuit breaker condition. It can replace the anti-pumping timer.

If at the end of the close pulse the circuit breaker has not closed, then the relay will raise a CB FAIL alarm then Lockout (section 2.5.2). If at the end of the close pulse, the circuit breaker has successfully closed then the relay will start the Reclaim Delay timer.

Reclaim

After the Circuit Breaker has been successfully reclosed the relay goes into the Reclaim state for the duration of the Reclaim delay, set by the *Auto-reclose:Reclaim Time* setting.

If within the Reclaim Delay a new fault occurs and a protection starter picks up, or if an external Arc Start SA input is raised, then the relay will continue the existing Protection/Auto reclose sequence as programmed.

If within the final Reclaim Delay a new fault occurs and a protection starter picks up, or if an external Arc Start SA input is raised, then the relay will apply the programmed last shot Protection characteristic, if any protection element operates a trip output will be issued then the relay will go to Lockout.

If the Reclaim Delay times out without another fault occurring then the relay will Reclaim i.e. reset, the sequence shot counter will be reset to zero and any subsequent fault will start a full new sequence.

At the start of a Reclaim Delay a 'Reclaim raised' event is generated. At the end of a successful Reclaim Delay a 'Reclaimed cleared' event is issued and an output is raised, this may be mapped by the user to any output relay using the *O/P Relay Config.:Reclaimed* setting.

Lockout

Lockout is a state where the relay truncates the current sequence or operation and resets leaving the Circuit Breaker Open and no further action is taken. The relay goes to the Lockout state when it reaches the last trip of a sequence without being able to clear a permanent fault or if conditions are such that a sequence or operation is truncated without completion. It is not necessary to reset the relay's Lockout state to be able to close the circuit breaker.

The number of Reclose attempts in any sequence before the relay locks out can be set by the User by the *Auto-reclose:P/F Shots To Lockout* setting. A sequence of up to four Close shots (five Trips) to Lockout may be set by the User. When Lockout is reached a Lockout event is issued and an output is raised as defined by the *O/P Relay Config.:Lockout Alarm* setting.

The *Auto-reclose:LO Recovery* delay inhibits all Close & Reclaim commands, from a status input or communications command, for a set time delay after lockout. The delay can be user selected to OFF, or to a set time delay. If set the delay prevents an operator from repeatedly quickly closing onto a permanent fault, allowing the Plant to cool between closes preventing overheating / overstressing.

Table 2-19 Auto-reclose from Internal Elements - Settings

Sub-menu: **Auto-reclose**

| Setting name | Range (bold = default) | Units | Notes |
|--|--|-------|--|
| Gn Line Check Trip | ON, OFF | | <i>Common setting, applies to all Sequences in that group</i> |
| Gn Seq Edit/View | 'ALL', 'P/F Sequence', 'E/F Sequence', 'SEF/REF Sequence', 'SA Sequence' | | <i>The settings below relating to P/F are repeated for E/F and SEF. This setting allows the user to display a subset of them only. Default depends on relay type. 'ALL' shows all settings</i> |
| Gn P/F [E/F][SEF] ARC | IN, OUT | | <i>These settings are for phase-fault elements; earth-fault (and where appropriate SEF) protection, have duplicate sets e.g. 'Gn P/F ARC' becomes 'Gn E/F ARC' or 'Gn SEF ARC'.</i> |
| Gn P/F [E/F][SEF] Line Check Trip | INST, DELAYED | | |
| Gn P/F [E/F][SEF] Protection Trip 1 | INST, DELAYED | | |
| Gn P/F [E/F][SEF] Reclose DTL 1 | 0.20, 0.21...2.0, 2.1... 3.0 ...20,21... 300, 360...3600, 3900...14400 | sec | |
| Gn P/F [E/F][SEF] Protection Trip 2 | INST, DELAYED | | |

| Setting name | Range (bold = default) | Units | Notes |
|-------------------------------------|--|-------|--|
| Gn P/F [E/F][SEF] Reclose DTL 2 | as Reclose DTL 1 | sec | |
| Gn P/F [E/F][SEF] Protection Trip 3 | INST, DELAYED | | |
| Gn P/F [E/F][SEF] Reclose DTL 3 | as Reclose DTL 1 | sec | |
| Gn P/F [E/F][SEF] Protection Trip 4 | INST, DELAYED | | |
| Gn P/F [E/F][SEF] Reclose DTL 4 | as Reclose DTL 1 | sec | |
| Gn P/F [E/F][SEF] Shots To Lockout | 1, 2, 3, 4 | | <i>For 4 reclose shots, 5 trips are issued – the fifth trip is always delayed.</i> |
| Gn P/F [E/F] HS1 Trips to Lockout | 1, 2, 3, 4, 5 | | <i>Not applicable to SEF sequence</i> |
| Gn P/F [E/F] HS2 Trips to Lockout | 1, 2, 3, 4, 5 | | |
| Reclaim Time | 0.20, 0.21... 2.0 , 2.1...20,21...300, 360...3600, 3900...14400 | sec | <i>Common setting across all Groups applies to all Sequences</i> |
| Close Pulse | 1.0, 1.1... 2.0 ...10.0 | sec | <i>Common setting across all Groups</i> |
| Manual Close Delay | OFF , 1, 2, 3, 4, 5, 6, 7, 8, 9, 10 | sec | <i>Common setting across all Groups</i> |
| LO Recovery | as 'Reclaim Time' | sec | <i>Common setting across all Groups</i> |

Sub-menu: **O/P Relay Config.**

| Setting name | Range (bold = default) | Notes |
|-------------------------|--|---------------------------------|
| Gn Lockout Alarm | _ or 1 for each output contact (default: _____ 1) | <i>Default output = relay 7</i> |
| Gn Close Pulse | _ or 1 for each output contact (default: _____ 1 _____) | <i>Default output = relay 4</i> |
| Gn AUX Close | _ or 1 for each output contact (default: _____) | <i>Default output = None</i> |
| Gn ARC Active | | |
| Gn Reclaimed | | |

Sub-menu: **Status Config.**

| Setting name | Range (bold = default) | Notes |
|--|--|-----------------------------|
| Gn CB Open | _ or 1 for each status input (default: _____ 1 _____) | <i>Default input = 6</i> |
| Gn CB Closed | _ or 1 for each status input (default: _____ 1 _____) | <i>Default input = 7</i> |
| Gn Reclose Block | _ or 1 for each status input (default: _____) | <i>Default input = None</i> |
| Gn P/F ARC Off | | |
| Gn E/F ARC Off Gn SEF/REF ARC Off | | |

2.9.1.2 External Protection Reclose Sequence

In addition to the relay's internal protection and auto-reclose sequences a programmable auto-reclose sequence and back-up protection functions for an external protection is provided.

The external protection trip is sensed on a status input, as set in the *Status Config:ARC Status A* setting. This will typically be energised from the trip output, or starter output, of an external protection device e.g. a distance protection or sensitive earth-fault relay. The Argus 4/6 will then provide a separate auto-reclose sequence, with the external protection providing the fault detection and tripping functions. Up to four close shots (five trips) to lockout may be set with independent reclose delays.

The *Auto-reclose:SA Trips to Block* setting causes an output to be raised after a set number of trips in a sequence as set in the *O/P Relay Config:SA Blocked* setting. This is intended to allow blocking of the external protection. For example, the Argus can provide the auto-reclose sequences and back-up IDMT protection to a distance protection. The distance relay could be allowed to trip twice, it can then be blocked and the IDMT protection of the Argus allowed to grade with other inverse protection relays to clear the fault.

Back-up protection is also provided by timers, as set by the *O/P Relay Config:Backup Alarm SA* and *O/P Relay Config:Backup Trip SA* settings, which run consecutively. When ARC Status A is raised, the Backup Alarm timer starts running, on time-out a *SA Alarm* is given and the Backup Trip timer then starts running, on its time-out the relay gives a *SA Trip* output. Both timers stop & reset when ARC Status A is cleared. This two stage back-up protection, therefore, has the external protection settings, e.g. Impedance or SEF levels. The timers provide a protection trip when the SA sequence has progressed to the point at which the external protection is blocked and the fault level falls below the overcurrent protection settings. For example; a five pole protection scheme can be engineered, with a 3P + E Argus 4 relay and a separate SEF relay, where the P/F, E/F, and SEF protection each have independent auto-reclose sequences.

Outputs from the alarm and trip are set using the *O/P Relay Config:SA Alarm* and *O/P Relay Config:SA Trip* settings.

All other settings relating to this function are as for the internal sequences described above, with the exception of line check trip. When the *Auto-reclose:SA Line Check Trip* setting is set to Delayed, the delay used is that given by the two stage back-up alarm and back-up trip times.

Table 2-20 Auto-reclose from External Trip SettingsSub-menu: **Protection**

| Setting name | Range (bold = default) | Units | Notes |
|---------------------------|-------------------------------------|-------|-------|
| Gn Backup Alarm SA | 0.00, 0.01... 10.00 ...20.00 | sec | |
| Gn Backup Trip SA | 0.00, 0.01... 10.00 ...20.00 | sec | |

Sub-menu: **Auto-reclose**

| Setting name | Range (bold = default) | Units | Notes |
|--|---|-------|--|
| Gn SA ARC | IN, OUT | | If set to <i>OUT</i> and an SA input occurs then the relay will go to <i>LOCKOUT</i> . |
| Gn SA Line Check Trip | INST, DELAYED | | |
| Gn SA Reclose DTL 1 Gn SA Reclose DTL 2 Gn SA Reclose DTL 3 Gn SA Reclose DTL 4 | 0.20, 0.21...2.00, 2.1, 2.2... 3.0 ...20.0, 21, 22...300, 360, 420...3600, 3900, 4200...14400 | sec | |
| Gn SA Shots To Lockout | 1, 2, 3, 4 | | |
| Gn SA Trips To Block | 1, 2, 3, 4, 5 | | |

Sub-menu: **O/P Relay Config.**

| Setting name | Range (bold = default) | Notes |
|----------------------|--|--------------------------|
| Gn SA Blocked | _ or 1 for each output contact (default: _ _ _ _ _) | Default output = None |
| Gn SA Alarm | | |
| Gn SA Trip | _ or 1 for each output contact (default: 1 _ _ _ _ _) | Default output = relay 2 |

Sub-menu: **Status Config.**

| Setting name | Range (bold = default) | Notes |
|------------------------|---|----------------------|
| Gn ARC Status A | _ or 1 for each status input (default: _ _ _ _ _) | Default input = None |

2.9.2 Control Inputs

The user enters the protection settings and auto-reclose sequence settings into the relay to set-up the required sequence for the different fault types, however, the operation of these functions may be modified or controlled by the programming inputs. These inputs may be via status inputs from external scheme logic and include blocking and CB Status inputs, or SCADA Control commands from the remote operator via the Communications link, or local commands via the *Linesman Mode* menu.

The Argus 2 and Argus 6 provide the following command set:

Trip and Lockout

When this command is raised (edge triggered) any existing auto-reclose sequence is aborted, a defined trip pulse is issued and the relay then goes to lockout.

Local Close and Reclaim

It is desirable that an Engineer should not be standing close to a Circuit Breaker when it is being closed, it could close onto a fault which could cause it to fail. This function inserts a Health and Safety time delay between the initiation by the operator of a Local Close & Reclaim command to the relay and the relay sending an output to the CLOSE circuit of the Circuit Breaker.

When a 'Local Close & Reclaim' command input (edge triggered) is raised the relay executes a 'CLOSE IN XX s' countdown timer before issuing the CLOSE pulse. The delay is set by the User in the *Auto-reclose:Manual Close Delay* setting, default OFF, to define the delay between the Command initiation being received by the relay and the CLOSE pulse being issued by the relay, thus allowing time for the operator to move away from the vicinity of the Circuit Breaker before it operates to close and make the circuit live.

When the CB is open and a CLOSE & RECLAIM command is raised, the relay jumps to the 'ARC Status' screen in which is displayed the count down timer 'CLOSE IN xx s' where the time 'xx s' is counted down from the User set Manual Close Delay value. On reaching the count of zero the CLOSE pulse is issued and the screen then shows the RECLAIM timer counting down after which 'RECLOSE SUCCESS' is displayed. Note:- the Manual Close delay starts when the mapped Status input is raised, clearing it and raising it again restarts the timer each time.

Application Note:- This function allows the normal panel mounted Circuit Breaker Control switch to initiate, via the relay, the delayed closing of the Circuit breaker thus removing complexity from the implementation of this Health and Safety feature.

If the CB is open the relay enables line check, then issues a defined close pulse and enters the reclaim delay. If

the CB closes onto a fault, or a fault occurs during the reclaim delay time, then the relay performs the programmed one trip to lockout.

The relay will not issue a close pulse to a circuit breaker that is indicating that it is closed, i.e. the double command status inputs CB Open is cleared and CB Closed is raised. If a Don't Believe It (DBI) condition exists, e.g. CB Open and CB Closed are both raised then the relay will issue the close pulse.

Remote Close and Reclaim

When this command is raised (edge triggered) if the CB is open the relay enables line check, then immediately issues a defined close pulse and enters the reclaim delay. There is no delay, as for Local Close & Reclaim, since there are tight 'Time allowed to live' limits on SCADA commands.

If the CB closes onto a fault, or a fault occurs during the reclaim delay time, then the relay performs the programmed one trip to lockout.

The relay will not issue a close pulse to a circuit breaker that is indicating that it is closed, i.e. the double command status inputs CB Open is cleared and CB Closed is raised. If a Don't Believe It (DBI) condition exists, e.g. CB Open and CB Closed are both raised the relay will issue the close pulse.

Trip and Auto-reclose

When this command is raised (edge triggered) the relay immediately issues a trip pulse then, after the first phase-fault reclose delay, it enables line check then issues a close pulse to reclose the circuit breaker and enters reclaim. If the CB closes onto a fault, or a fault develops during reclaim, then the relay will perform the line check one trip to lockout. This command is typically used for a routine test of the Trip and Close operations of the Circuit Breaker.

Close and Lock-in

When this command is raised (edge triggered) if the CB is open the relay immediately issues a defined close pulse and then inhibits all Protection and Autoreclose functions. This allows the circuit breaker to be operated as a switch without protection trip functions.

Table 2-21 Auto-reclose Commands Settings

Sub-menu: **Auto-reclose**

| Setting name | Range (bold = default) | Units | Notes |
|---------------------------|---------------------------------|-------|-------|
| Manual Close Delay | OFF , 1, 2...10 | sec | |

Sub-menu: **Status Config.**

| Setting name | Range (bold = default) | Units | Notes |
|-------------------------------------|---|-------|-------|
| Gn Trip & ARC | _, 1 for each status input (default: _____) | | |
| Gn Close & Lockin | _, 1 for each status input (default: _____ 1 _) | | |
| Gn Trip & Lockout | _, 1 for each status input (default: _____ 1 _) | | |
| Gn Local Close & Reclaim | _, 1 for each status input (default: _____ 1) | | |
| Gn Remote Close Reclaim | _, 1 for each status input (default: _____) | | |

2.9.3 Frequent Operations Counter

Argus 4 & 6 relays incorporate a Frequent Operations Counter (FOC) which operates to prevent cyclical operations caused by multiple fault re-occurrences or by setting interactions between AutoReclosers at different points in the system in response to a permanent fault. While the FOC is exceeded it will act to truncate and modify a sequence to break the cyclical operation. The FOC also acts to limit the number of Circuit Breaker operations per hour to the value set by the User.

For further details see section 2.14.1.4.

2.9.4 Hot (Live) Line Working

When maintenance is being performed on an overhead line, or new equipment is being added, it can be inconvenient or impractical to make the line dead. Live line working can be performed using special tools and equipment. When live line working is being performed all auto-reclose sequences should be inhibited and any fault must force an instantaneous Trip to Lockout.

The hot line working mode is enabled from a status input (as defined by the *Status Config: Hot Line Working* setting), from the relay's *Linesman Mode* (section 2.15), or via the IEC communications link. For hot line working to be disabled none of these inputs can be on.

In the hot line working mode, if fault current above any starter setting is seen, the relay will give a single instantaneous trip and lockout overriding all protection/auto-reclose settings and inhibits.

Table 2-22 Live Line Working Setting

Sub-menu: **Status Config.**

| Setting name | Range (bold = default) | Units | Notes |
|----------------------------|--|-------|-------|
| Gn Hot Line Working | _, 1 for each status input (default: _____) | | |

2.10 Trip Circuit Supervision

One, or more, trip circuits can be monitored by connecting a status input in each trip circuit to be supervised, e.g. as shown in the application diagram

Figure 3.8-1 & 3-9 The inputs are specified with the *Status Config: Trip Circuit Fail* setting.

If all mapped status inputs are energised (raised) then the trip circuits are considered healthy. If any trip circuit loses auxiliary supply, or becomes high resistance or open-circuit, then the wired status input will be de-energised (cleared) and a trip circuit fail alarm and indication raised.

Local indication will be in the form of a message on the LCD, e.g. 'Trip Circuit FAIL S1+3' if the trip circuits associated with status inputs 1 and 3 have failed.

By mapping each trip circuit fail status input to a changeover contact an alarm output can also be generated from the normally-closed contact. A suitable pick-up delay should be set on the status input. More details about the application of trip circuit supervision are given in the Application Notes - Section 3.8.

Table 2-23 Trip Circuit Supervision Settings

Sub-menu: **Status Config.**

| Setting name | Range (bold = default) | Units | Notes |
|-----------------------------|--|-------|-------|
| Gn Trip Circuit Fail | _, 1 for each status input (default: _____) | | |

2.11 Status inputs and Relay Outputs

The status inputs and relay outputs are all user-programmable. The settings related to each function are described in the relevant section of this document. The relevant Diagrams and Parameters document for each Argus series provides matrix diagrams that allow user mappings of the status inputs and output relays to be recorded.

It is possible to map status inputs to directly operate relay outputs, using the *O/P Relay Config: Status n* settings.

The operation of the status inputs and output relays is described below and shown in Figure 2.11-1 and Figure 2.11-2 respectively.

Hand Reset Output Relays

Relay outputs are self-resetting by default; however, each relay output can be individually set to hand reset. In this case, the relay latches on operation and can be released by using the TEST/RESET key on the relay fascia (from the *Identifier* screen), by the communications link, or by energising a status input - as mapped by *O/P Relay Config: Reset Flags & Outputs*.

Pulsed Output Relays

Argus 4 and Argus 6 only.

Output relays can be set as pulsed by the *O/P Relay Config: Pulsed Relays* setting. Rather than remaining energised for the period that any mapped output signal is activated, a pulsed output relay will be energised for the minimum energise time, see Table 2-24, and will then be de-energised. It will remain de-energised until the output signal is deactivated and reactivated, whereupon another pulsed output will occur.

Output Relay Minimum Energise Time

All relay outputs can have their minimum energise time set by the *Q/P Relay Config.:Min O/P Energise Time*.

Status Input Inversion and Delays

Each status input can be set to inverted action i.e. the internal signal is raised when the input is de-energised and cleared when energised, using the *Status Config.:Inverted Inputs* setting.

Each status input can also be programmed with a pick-up and drop-off delay, using the *Status Config.:Status n P/U Delay* and *Status Config.:Status n D/O Delay* settings. The pick-up and drop-off delays are applied following the inversion, i.e. pick-up delay applies to the input becoming active, while drop-off applies to it becoming inactive.

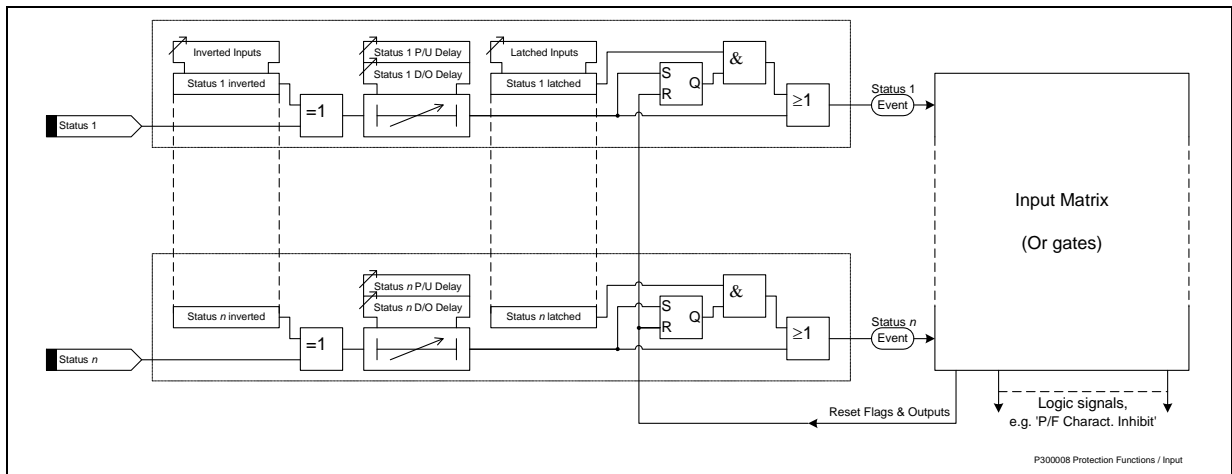

Figure 2.11-1 Status Input Logic

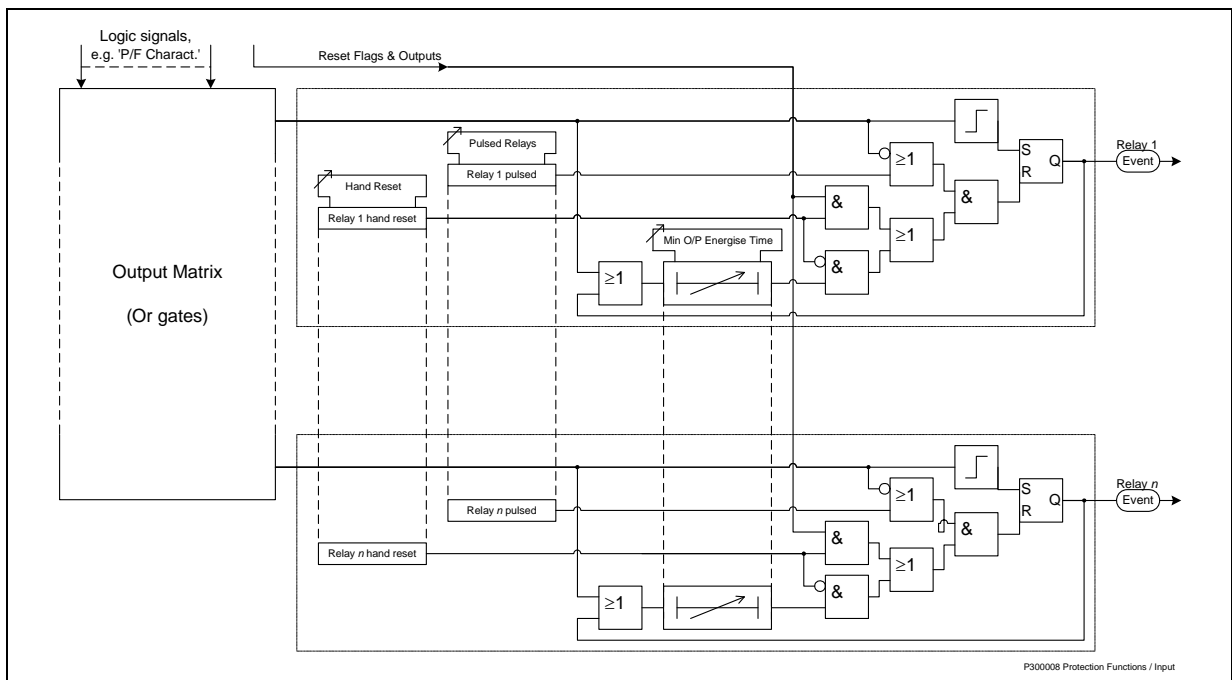

Figure 2.11-2 Output Relay Logic

Table 2-24 General Output Relay and Status Input Settings

Sub-menu: **O/P Relay Config.**

| Setting name | Range (bold = default) | Units | Notes |
|---|---|-------|---|
| Gn Status 1 Gn Status 2 ... Gn Status n | _, 1 for each output contact (default: _ _ _ _ _) | | <i>n is the number of status inputs present</i> |

| Setting name | Range (bold = default) | Units | Notes |
|-------------------------------|---------------------------------|-------|----------------------------------|
| Gn Hand Reset | | | |
| Gn Pulsed Relays | | | <i>Argus 4 and Argus 6 only.</i> |
| Min O/P Enegerise Time | 100 , 150...500 | ms | |

Sub-menu: **Status Config.**

| Setting name | Range (bold = default) | Units | Notes |
|---|--|-------|---|
| Inverted Inputs | _, 1 for each status input (default: _____) | | |
| Latched inputs | | | <i>Argus 4 and Argus 6 only.</i> |
| Gn Status 1 P/U Delay Gn Status 1 D/O Delay Gn Status 2 P/U Delay Gn Status 2 D/O Delay ... Gn Status n P/U Delay Gn Status n D/O Delay | 0.00, 0.01, 0.02...2.0, 2.1...20, 21... 300, 360...3600, 3900...14400d | sec | <i>Default settings of 0.02 for pick-up and 0.01 for drop-off are applied to give AC rejection. n is the number of status inputs present.</i> |
| Gn Reset Flag & Outputs | _, 1 for each status input (default: _____) | | |

2.12 Communications

All settings and information relating to communications with the Argus, are given in Section 4: Communication Interface.

2.13 Data Storage

Argus relays store three types of data to assist the user in fault evaluation i.e. events, waveforms and faults.

2.13.1 Event Storage

When an event occurs a date and time tagged entry is added to the storage buffer. Some of the events that can be stored are indicated in the function diagrams throughout this functional description section. Up to 500 events are stored in a rolling buffer, with the oldest events overwritten. The buffer can be cleared using the *Data Storage:Clear All Events* setting.

All events can be obtained through the communications link and are displayed in the Reydisp Evolution package in chronological order, allowing the user to see the sequence of events surrounding a trip. They are also made available spontaneously to a compliant control system.

For a complete listing of events available in each model refer to the appropriate Diagrams and Parameters document.

2.13.2 Fault Data Record

A Fault Data Record is a time-tagged textual record of the conditions at the instant of a Fault Trigger e.g. Trip, Table 2-25 shows all possible entries in a fault record. Details are included of all operated or operating protection elements, magnitudes and directions of currents in each pole at the time of trip.

A Fault Data record is triggered when any output relay, as designated in the *Data Storage:Gn Fault Trigger* setting, operates in combination with any protection element, or a status input mapped to a Fault Trigger output relay is raised. To trigger a Fault Data record from an external protection device connect its trip output to a status input which is mapped to a *Data Storage:Gn Fault Trigger* output relay.

Note. Unless an output relay is set=1 in the *Data Storage:Fault Trigger* setting then no fault data record will be stored when a protection function assigned to that output relay operates.

Up to 5 faults are stored in a rolling buffer, with oldest faults overwritten. All Fault Data records can be cleared if *Data Storage:Clear All Faults* is set to *YES*.

Table 2-25 List of Entries for Fault Data Records

| Type | Fault Record Entry | Description |
|-------------|---------------------------|-------------|
| Date & Time | dd/mm/yy hh:mm:ss.ssss | Time stamp |

| Type | Fault Record Entry | Description | |
|----------------|--|---|---|
| Group | Gn | Active setting group at time of trip, where n is the group number | |
| Poles | PHASE A, PHASE B, PHASE C, EARTH FAULT, SEF, REF | | |
| | Direction | FWD (or user tag) REV (or user tag) | Forward and reverse direction. User-defined text tags can be programmed for each direction, e.g. LINE, BUS, FEEDER, TRANSFORMER, etc. |
| | Elements | LS | Lowset |
| | | DTL | Time-delayed characteristic (set to DTL) |
| | | IDMTL | Time-delayed characteristic (set to IDMTL) |
| | | HS1 | Highset 1 |
| | | HS2 | Highset 2 |
| | | TIMER 1 | SEF/REF 1 st time delay |
| | | TIMER 2 | SEF/REF 2 nd time delay |
| | | EXTERNAL TRIP | Trip generated externally and monitored through status input |
| | | CB FAIL 1 | Circuit breaker fail re-trip |
| | | CB FAIL 1 + 2 | Circuit breaker fail back-trip |
| | | <XX> | Element shown e.g. '< IDMTL >' raised the fault trigger |
| | Current | IA=xxx | Current of phase A is xxx |
| | | IB=xxx | Current of phase B is xxx |
| | | IC=xxx | Current of phase C is xxx |
| | | IE=xxx | Current of earth-fault pole is xxx |
| | | ISE=xxx | Current of sensitive or restricted earth-fault pole is xxx |
| | Voltage | VA=xxx | Voltage of phase A is xxx |
| | | VB=xxx | Voltage of phase B is xxx |
| VC=xxx | | Voltage of phase C is xxx | |
| VN=xxx | | Neutral displacement voltage is xxx | |
| Auto-reclose | TRIP & RECLOSE | Autoreclose following trip | |
| | HOT LINE LOCKOUT | Recloser locked out following trip, due to hot line working active | |
| | TRIP & LOCKOUT | Recloser locked out following trip | |
| | LINE CHECK TRIP | Trip due to switch onto fault | |
| | SA TRIP | External trip | |
| General Alarms | (user defined text tag) | A user-defined text tag can be programmed, e.g.' BUCHHOLZ TRIP '. Multiple Alarms are concatenated with ' + ' symbols | |

Example

'12/05/04 17:25:51.2525 G1 PHASE A LS IDMTL <HS1> HS2 IA = 12.32xIn, PHASE B LS IDMTL HS1 HS2 IB = 12.23xIn, PHASE C LS IC=0.78xIn, EARTH FAULT LS IDMTL IE=0.27xIn', BUCHHOLZ TRIP

This specifies the date and time of the trip and that settings group 1 was active at the time of trip. On phase A the lowset, delayed characteristic, and highsets 1 and 2 were picked up. Phase A highset 1 issued the trip/fault trigger. Phase A current was 12.32 xIn. On phase B the lowset, delayed characteristic, highset 1 and highset 2 were picked up with a current of 12.23 xIn. On phase C the lowset element was picked up with a current of 0.78 xIn. The earth-fault lowset and delayed characteristic elements were picked up with a current of 0.27 xIn, and a General alarm 'BUCHHOLZ TRIP' was raised. Basically a Phase A to B fault with some Earth fault component, Phase C unfaulted.

2.13.3 Waveform (Disturbance) Records

Waveform Record storage is a digital graphical record of analogue current (and for Argus 2 type II voltage) inputs, status inputs and relay outputs.

Each record is one second in length and is triggered from a protection element operating or from a status input as designated in the *Data Storage:Waveform Trig* setting. This allows the user to specify one or more trigger methods:

phase fault (P/F), earth-fault (E/F), SEF, Status input (STA) and/or Voltage element operation. When status input trigger is selected, the inputs used are specified by the *Status Config:Waveform Trig* setting.

Note. Unless the correct settings are applied as described above then no waveform record may be stored in the event of a fault.

When storage is triggered some pre-trigger waveform may be stored, the percentage of which is specified by the *Data Storage:Waveform Pre-Trigger* setting. Suggested setting is 80% pre-trigger.

Up to 5 waveforms are stored in a rolling buffer, oldest waveforms are overwritten by new. The waveform storage can be cleared if *Data Storage:Clear All Waveforms* is set to *YES*.

2.13.4 Maximum Demand Function

This feature enables the relay to perform an average and maximum demand function of the following measured quantities:

IA

IB

IC

Watts – AG2-5* only

VArS – AG2-5* only

There are two user configurations for this feature: -

The first is a rolling window which measures the average quantities over a rolling window of 'n' minutes. i.e. as new values are added old values are removed from the sum – the average is calculated constantly.

The second method is a fixed window where the sum is reset at the start of the window and incremented with new values until the end of the window period. Upon reaching the end of the window the average is calculated and a new window started.

The average and maximum quantities are reported with new instruments, one for each quantity, i.e. one screen would show:

| | | |
|--------------------------------|----|---------------------------------|
| IA MAX = 300.0 ROLL = 176.0 | or | IA MAX = 300.0 FIXED = 176.0 |
|--------------------------------|----|---------------------------------|

The display depends upon the window type. The size of the window can be set by the user with the *Data Storage:Demand Window = xxxx* minutes setting. The maximum quantities do not have any relationship to the window and will report the maximum quantities since the last user reset of this function. Resetting the quantities can be done either from the setting 'Maximum Demand Reset', the instruments screen, or via an IEC60870 comms command.

Table 2-26 Data Storage Settings

Sub-menu: **Status Config.**

| Setting name | Range (bold = default) | Units | Notes |
|-------------------------|--|-------|--|
| Gn Waveform Trig | _, 1 for each status input (default: _____) | | <i>The trigger must also be set to STAtus in the Data Storage menu.</i> |

Sub-menu: **Data Storage**

| Setting name | Range (bold = default) | Units | Notes |
|--------------------------------|---|-------|---|
| Gn Fault Trigger | _, 1 for each output contact (default: _ 1 _____) | | |
| Gn Waveform Trig | _, 1 for each of P/F, E/F, SEF, STAtus , V (default: _____ all Off) | | <i>'V' applies only to Argus 2 type II.</i> |
| Gn Waveform Pre-Trigger | OFF, 10 , 20...100 | % | <i>Suggested setting 80%</i> |
| Clear All Waveforms | NO , YES Self-resetting | | <i>Yes/No confirmation required</i> |
| Clear All Events | | | |
| Clear All Faults | | | |
| Demand Window Type | OFF , ROLLING, FIXED | | |

| Setting name | Range (bold = default) | Units | Notes |
|-----------------------------|--|-------|------------------------------|
| Demand Window | 5, 10, 15 .. 60, 90 .. 300, 360 .. 1440 | mins | |
| Maximum Demand Reset | NO , YES Self-resetting | | Yes/No confirmation required |

Sub-menu: **CB Maintenance**.

| Setting name | Range (bold = default) | Units | Notes |
|---------------------------|---------------------------------|-------|---|
| Energy Meter Reset | NO , YES Self-resetting | | V' applies only to Argus 2 type II. Yes/No confirmation required |

2.14 Maintenance

This section covers features to assist in the maintenance of circuit breakers, the protection scheme and the Argus relay itself.

2.14.1 Circuit Breaker Operations

Trip counts and I^2 summation occur for each internal or external trip, as specified by Data Storage:Fault Trigger, see section 2.13.2.

2.14.1.1 Trip Counter

A trip counter is provided which increments on each trip command issued.

A suitable maintenance limit value can be chosen from the circuit breaker manufacturer's data and entered into the CB Maintenance:Trip Counter Alarm setting. When the alarm setting is exceeded, the output relays mapped by O/P Relay Config:Trip Counter Alarm are raised.

The count can be reset using CB Maintenance:Trip Counter Reset, or when viewing the counter's instrument.

2.14.1.2 Sum of I^2

Circuit breaker contact wear increases with energy broken, therefore I^2 summation provides a good estimation for maintenance purposes. A suitable maintenance limit value can be chosen from the circuit breaker manufacturer's data and entered into the CB Maintenance: ΣI^2 Alarm setting.

The current flowing at the time of trip is added to individual summations for each phase. If any of these exceed the alarm setting, the output relays mapped by O/P Relay Config: ΣI^2 Alarm are raised. An instrument shows the largest I^2 summation of the three phases.

The summation can be reset using CB Maintenance: ΣI^2 Reset, or when viewing the summation instrument.

2.14.1.3 Delta Trip Counter

Argus 4 and Argus 6 only

This provides an additional counter, which can be reset independently of the Trip Counter described above. This can then be used, for example, for recording trip operations between visits to a substation.

Its operation is similar to the Trip Counter above, however a different limit setting (CB Maintenance:A Trip Counter Alarm) and output (O/P Relay Config:A Trip Alarm) are provided.

The delta trip counter can be reset using CB Maintenance:A Trip Counter Reset and when viewing the counter's instrument, also by a status input mapped by Status Config:A Trip Counter Reset.

2.14.1.4 Frequent Operations Counter

Argus 4 and Argus 6 only

Argus 4 and 6 relays incorporate a Frequent Operations Counter (FOC) which logs the number of trip operations in each minute-window in a rolling window of one hour. When the total number of trip operations in one hour reaches or exceeds that set by the user in the CB Maintenance:Freq Op Counter Alarm setting then all protection and auto-reclose settings are replaced by a Delay (+HS1+HS2 if applicable) characteristic and one trip to lockout operation. The normally active protection and sequence settings are suspended until the total number of operations decrements to below the counter setting as the rolling one hour window drops off the high trip count minute-windows.

The standing number of FOC trips and the FOC Alarm level are displayed in the *Instruments:Freq Op Counter*. The FOC counter can be reset using *CB Maintenance:Freq Op Counter Reset*, when viewing the counter's instrument, or by raising a status input mapped to *Status Config.:FOC Reset*.

Table 2-27 Circuit Breaker Maintenance Settings

Sub-menu: **CB Maintenance**

| Setting name | Range (bold = default) | Units | Notes |
|-------------------------------|--|-----------------|---------------------------|
| Δ Trip Counter Reset | NO , YES | | Argus 4 and Argus 6 only. |
| Δ Trip Counter Alarm | OFF , 1, 2...999 | | |
| Trip Counter Reset | NO , YES | | |
| Trip Counter Alarm. | OFF , 1, 2...999 | | |
| Freq Op Counter Reset. | NO , YES | | Argus 4 and Argus 6 only. |
| Freq Op Counter Alarm | OFF , 1, 2...999 | | |
| ΣI² Reset | NO , YES | | |
| ΣI² Alarm | OFF , 10, 11...100, 110... 20000, 21000...100000 | MA ² | |

Sub-menu: **O/P Relay Config.**

| Setting name | Range (bold = default) | Units | Notes |
|--------------------------------|--|-------|---------------------------|
| Gn ΔTrip Alarm | | | Argus 4 and Argus 6 only. |
| Gn Counter Alarm | _, 1 for each output contact (default: _____) | | |
| Gn ΣI² Alarm | | | |
| Gn FOC Alarm | | | Argus 4 and Argus 6 only. |

Sub-menu: **Status Config.**

| Setting name | Range (bold = default) | Units | Notes |
|---------------------------------|--|-------|---------------------------|
| Gn ΔTrip Counter Reset | | | Argus 4 and Argus 6 only. |
| Gn Counter Reset | _, 1 for each status input (default: _____) | | |
| Gn FOC Reset | | | Argus 4 and Argus 6 only. |
| Gn ΣI² Update | | | |

2.14.2 Output Relay Test

The output relay test allows the Argus to simulate a particular element operation, e.g. P/F Highset 1, and energise all output contacts that would normally be energised from that element output. This is useful during commissioning/routine tests, so that wiring and operational checks can be performed without the need for secondary injection.

The required element is selected from the list available in the *CB Maintenance:O/P Relay Test* setting. Scroll to that setting, press ENTER, select the required element name using the up or down keys, press ENTER to select, a confirmation screen ' ** O/P Test ** Are You Sure ? N ' will be shown, confirm by using the up or down key to change to ' Y ' and press ENTER. An active countdown timer will then be shown in a ' ** TRIP TEST IN** , ** xx SECONDS ** ' screen. The counter decrements from 10 seconds to zero, then all output relays mapped to that element are energised for 100ms, then a message TRIP TEST FINISHED is briefly displayed.

The time delay before output relay energisation allows personnel to leave the vicinity of the circuit breaker before a live system trip test is performed.

Table 2-28 Output Relay Test Setting

Sub-menu: **CB Maintenance**

| Setting name | Range (bold = default) | Units | Notes |
|--------------|---------------------------------|-------|-------|
| | | | |

| Setting name | Range (bold = default) | Units | Notes |
|-----------------------|---|-------|---|
| O/P Relay Test | OFF , Protection Healthy, all P/F, E/F, SEF overcurrent element outputs all voltage elements, all mapped status, Alarms, counters, hand & pulsed relays, Lockout alarm, Close pulse, Aux Close, ARC active, Reclaimed, SA Blocked, SA Alarm, SA Trip, | | YES / NO confirmation is required. |

2.14.3 Internal Supervision

The Argus relay applies comprehensive supervision of its internal operation, both hardware and software. In the event of any failure all outputs are de-energised and the relay is shut down in a controlled manner. Supervision includes a power supply watchdog, code execution watchdog, memory checks by checksum, memory addressing checks and processor and ADC health checks.

While the relay is healthy an output can be given as specified by the *Output Relay:Prot. Healthy*, setting. By allocating this output to a normally closed contact, i.e. any output relays 1 to 3, an alarm can be generated by relay de-energisation or Protection Healthy failure. Note: relay withdrawal will also generate an alarm as all normally closed contacts have 'CT' shorting contacts which close when the relay is withdrawn from its case.

If an internal failure is detected a relevant identifying message will be displayed if possible and the Argus will reset and restart in an attempt to restore normal operation, this will result in de-energisation of the protection healthy contact and flashing of the protection healthy LED. Reset takes about 2 - 3 seconds.

Each time power is applied to the relay or the relay resets, internal Power On and Reset counters are incremented; the total count is shown in *Instruments:Power On Count*. An alarm level can be set in the *CB Maintenance:Power On Count Alarm* and an output will be raised if the count is exceeded, this can be mapped to an output relay *Output Relay:Power On Count*. This can be useful in tracing problems with substation batteries or relays. The count can be reset either from the Instrument display by pressing TEST/RESET, use up /down keys to confirm ' Y ', press TEST/RESET again; or, from the CB Maintenance menu using the ENTER and up /down keys to select ' Y ' and confirm.

Table 2-29 Internal Supervision Setting

Sub-menu: **O/P Relay Config.**

| Setting name | Range (bold = default) | Units | Notes |
|-------------------------|---|-------|-------|
| Gn Prot. Healthy | _, 1 for each output contact (default: 1 _ _ _ _ _) | | |
| Gn PowerOn Count | _, 1 for each output contact (default: 1 _ _ _ _ _) | | |

Sub-menu: **CB Maintenance**

| Setting name | Range (bold = default) | Units | Notes |
|-----------------------------|---------------------------------|-------|---|
| Power On Count Reset | NO , YES | | YES / NO confirmation is required. |
| Power On Count Alarm | OFF , 1, 2...999 | | |

2.15 Linesman Mode

Argus 4 and Argus 6 only

Linesman mode is a special mode available on Argus 4 and Argus 6 relays which provides a limited command set that is intended to allow a user (Linesman) simple access to enable and disable various features when working on the line, particularly for live line working.

Access to a selected set of settings from various parts within the menu system is provided in the *Linesman Mode* menu, together with some commands. These settings differ slightly from other settings in that they are not password protected and can be accessed and changed using the right (►) key, this allows them to be set with the relay front cover in place.

The linesman mode is easily reached from the top of the menu tree using the down (▼) key.

If the linesman mode is not required it can be hidden using *System Config::Linesman Display*, which is password protected. This setting allows a controlling setting such as *SEF OFF* to be set and then hidden such that it cannot accidentally, or easily, be turned back on again

Table 2-30 Linesman Mode Setting

Sub-menu: **System Config.**

| Setting name | Range (bold = default) | Units | Notes |
|-------------------------|--------------------------------|-------|---|
| Linesman Display | VISIBLE , HIDDEN | | <i>If attempts are made to access Linesman mode when it is set to Hidden the Display will show 'Linesman Display ' hidden'</i> |

Table 2-31 Linesman Mode Settings and Commands

| Setting name | Range (bold = default) | Units | Note:- <i>YES / NO</i> confirmation required. |
|----------------------------|--------------------------------|-------|--|
| Scada Control | OFF, ON | | |
| Hot Line Working | OFF , ON | | <i>Set to ON for live line working. When set 'On', detection of a fault causes an instantaneous trip and lockout.</i> |
| Trip & Lockout | NO , YES | | <i>Normally set to 'NO', set to 'YES' and confirm Y to carry out command.</i> |
| Trip & Reclose | | | |
| Close & Reclaim | | | |
| ARC | OFF, ON | | |
| Inst. Lowset | OFF , ON | | |
| Trip Counter Reset | NO , YES | | |
| SEF | OFF, ON | | |

Section 3: Application Notes

3.1 Selection of Characteristics

In most applications, especially where the relay must grade with other IDMTL relays on the system, the characteristic curve is selected to be the same type as the others - e.g. most relays have normal inverse curves type A to IEC 60255-3 and this would be the usual choice on the Argus relay. Extremely inverse curves type C to IEC 60255-3 are often used to grade with fuses or moulded case circuit breakers. Operating times become slower higher up the system due to the required grading margins between characteristics and VI and NI characteristics are needed. Long Time Inverse can be used for thermal protection.

The Argus relay measures true RMS values of current and for this reason can be used to protect capacitor banks or other circuits where harmonics are significant.

Each pole has four independent overcurrent stages and each stage may be instantaneous or time lagged. When grading with fuses, these characteristics may be combined to give a composite curve to correctly co-ordinate.

The use of an instantaneous element is common on transformer protection to give fast clearance of terminal faults. In some instances, such as a feeder that is cabled from a substation and then becomes an overhead line, the highset can be selected to operate only for cable faults and can be utilised to block auto-reclosing.

Argus relays can be supplied with sensitive earth-fault or restricted earth-fault functions. Refer to the VA TECH Reyrolle ACP Application Guide on REF for details.

3.1.1 Reset Delay

The increasing use of plastic insulated cables, both conventionally buried and aerial bundled conductor, have given rise to the number of flashing intermittent faults on distribution systems. At the fault position the plastic melts and temporarily reseals the faulty cable for a short time after which the insulation fails again. The same phenomenon has occurred in compound-filled joint boxes where an internal flashover temporarily reseals.

The repeating process of the fault often causes electromechanical disc relays to “ratchet” up and eventually trip the faulty circuit if the reset time of the relay was longer than the time between successive flashes. Early electronic IDMTL relays with instantaneous reset features were not at all effective in dealing with this condition and only tripped after the flashing fault had developed into a solid permanent fault.

To overcome this the Argus relay has a reset that can be user programmed to be either instantaneous or delayed from 1 to 60 seconds in 1-second steps. Where Argus relays are used to protect cable feeders, it is recommended that a 60 second reset delay be used.

On overhead line networks, particularly where reclosers are incorporated in the protected system, instantaneous resetting is desirable to ensure that, on multiple shot reclosing schemes, correct grading between the source relays and the relays associated with the reclosers is maintained.

3.2 Directional Protection

Argus 2 and Argus 6 relays incorporate discrete directional elements with comprehensive selection so that each of the 4 current measuring devices can be selected to be either non-directional, forward directional, reverse directional or bi-directional. In the bi-directional mode, separate sets of settings can be assigned to the forward and reverse elements. For example, the IDMTL function could be set to be 100% 0.4 time multiplier in the forward direction and 15% 0.1 time multiplier in the reverse direction. Similarly, each of the Low Set and High Set elements can have different current and time settings in each direction and each of the elements can be mapped to any output relay(s).

Convention dictates that forward direction refers to power flow away from the busbar, while reverse direction refers to power flowing towards the busbar.

3.2.1 Parallel or Ring Feeder Protection

Consider the network shown in Figure 3.2-1.

Circuit breakers at E and G would have Argus 2/6 relays installed, set to bi-directional. The E & G reverse IDMTL elements must be set to grade with the forward settings on the load circuit breaker relays and the C & D forward element settings; the E & G forward IDMTL elements are set more sensitive, i.e. with lower current and time multiplier settings to detect feeder faults.

For a fault as shown, close to the load substation, the currents at breakers C and D will have similar levels and their associated Argus relays will have prospective operate times of the same order. For the anti-clockwise fault current flow through C, G FWD must be set to be faster than E REV which in turn must be faster than C (FWD). Relay G will thus Trip first on FWD settings to stop the back feed of the fault, leaving D (FWD) to operate to clear the fault and the un-faulted Feeder C maintains power to the load.

If the fault occurred on feeder C, then clockwise fault current will flow through D, E FWD must be set to be faster than G REV which in turn must be faster than D. Relay E will thus Trip first on FWD settings to stop the back feed of the fault, leaving C (FWD) to operate to clear the fault and the un-faulted Feeder D (FWD) maintains power to the load.

Relays at C and D at the main substation could be set to non-directional but by setting them to be directional, the bi-directional function enables different settings to be applied for feeder and busbar faults. At A and B, bi-directional relays enable sensitive settings to be applied to the forward direction to detect transformer faults whilst reverse settings can be graded with forward settings at C and D.

By using a single bi-directional Argus relay, with different settings for forward and reverse directions, complex ring circuits can be set to grade correctly whether fault current flows in a clockwise or counter clockwise direction, i.e. only one relay must be used where normally two relays are required. The same applies to Generator circuits.

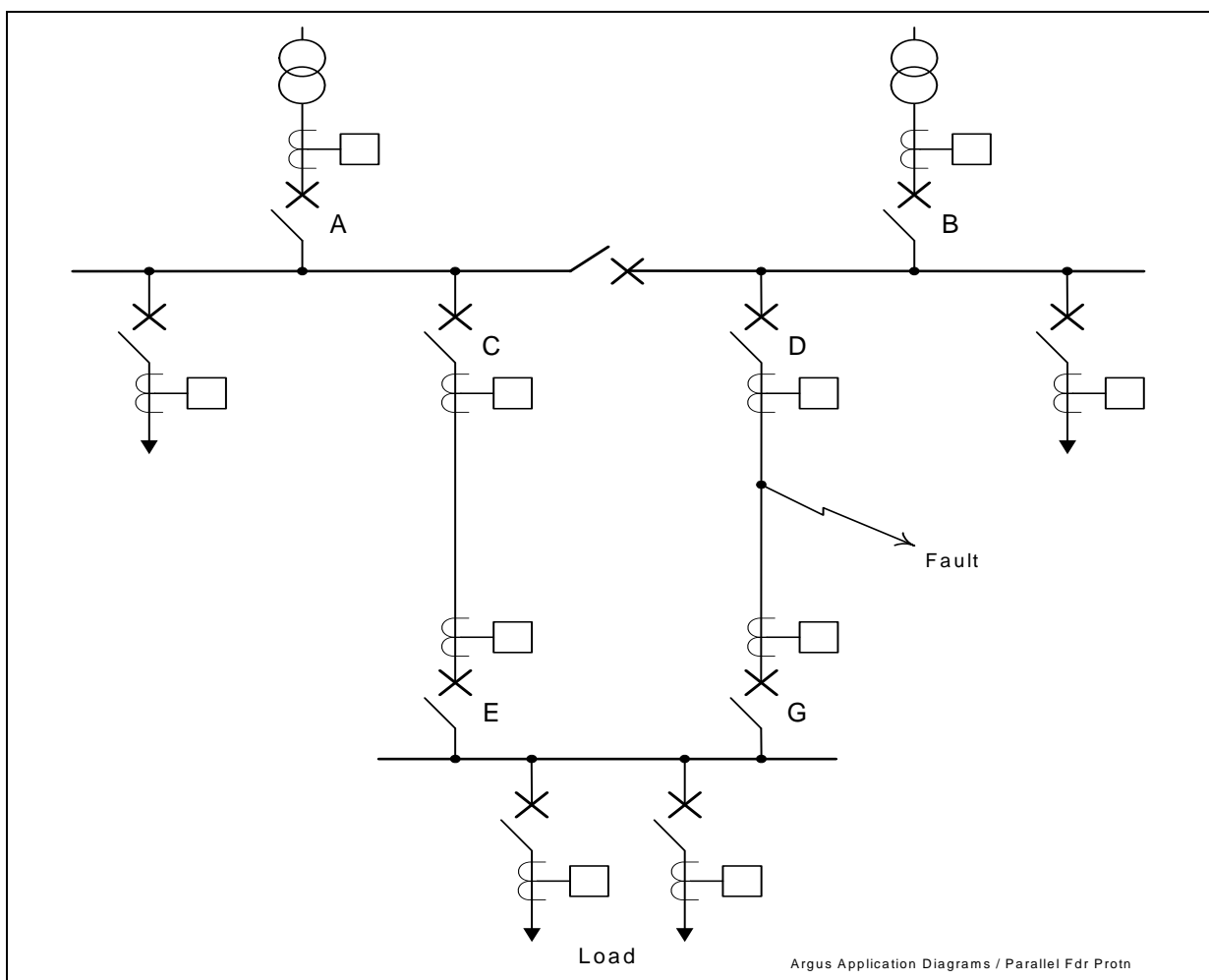

Figure 3.2-1 Parallel Feeder Protection

3.3 Sensitive Earth-fault Protection

Where sensitive earth-fault settings are required, the setting must be above any line charging current levels that can be detected by the relay.

On occurrence of an out of zone earth fault the elevation of sound phase voltage to earth in a non-effectively earthed system can result in a zero sequence current of up to 3 times phase charging current flowing through the relay location.

The step change from balanced 3-phase charging currents to this level of zero sequence current includes transients. It is recommended to allow for a transient factor of 2 to 3 when determining the limit of charging

current. Based on the above considerations the minimum setting of a relay in a resistance earthed power system is 6 to 9 times the charging current per phase.

3.4 Blocking Schemes

Where substations in a radial network are physically close, such as on the MV system in a power station, and pilot cables can be economically run between switchboards, the times set on a particular relay and an upstream relay can be made identical. This reduces the fault clearance time by eliminating the grading margin delay. To achieve this, the Overcurrent starter contact of the downstream relay is connected via pilot wires to Block (inhibit) the upstream relay. Grading is ensured by this blocking feature provided that the upstream tripping time is set to be longer, with margin, than the time taken for the downstream blocking signal input to be raised. Figure 3.4-1 illustrates the scheme.

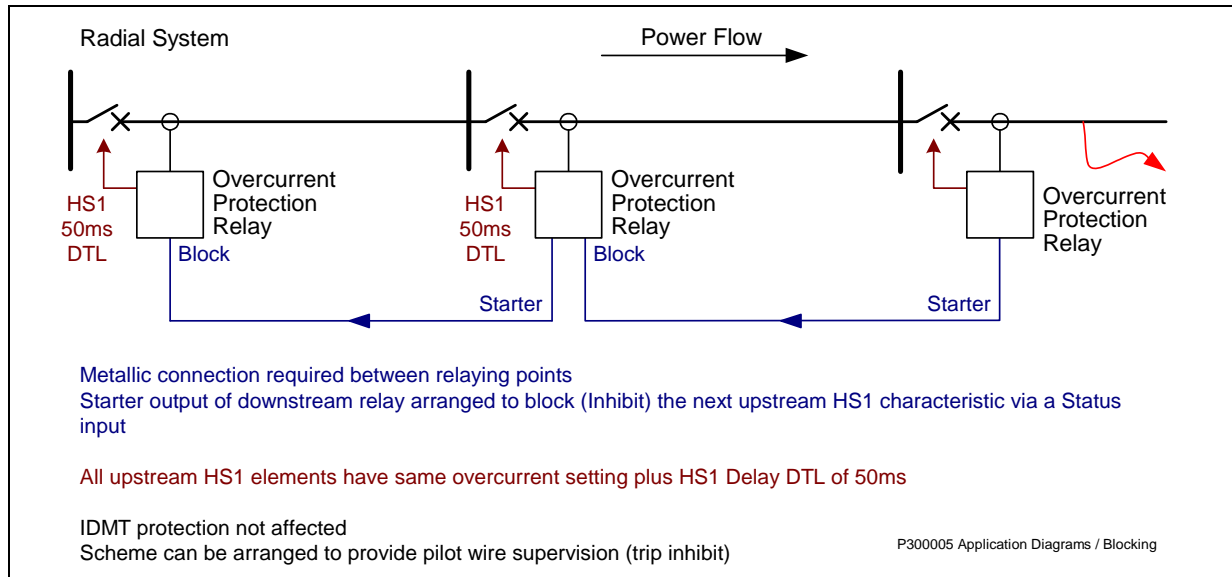

Figure 3.4-1 Blocking scheme giving fast fault clearance

This example shows the use of a "starter" output to block a Highset protection function for a circuit breaker nearer to the source. Type tests have shown that with a time delay as low as 40ms on the upstream Highset function that grading is ensured preventing the upstream relay instigating a trip. For security reasons a minimum time delay of 50ms is recommended, typically 100ms can be used. The Blocking Status input used to inhibit the HighSet function should have 10ms Pick-up and Zero Drop-off delay settings to give fast operation but a.c. pick-up rejection.

The example, shown in Figure 3.4-1, also proposes the use of IDMTL functions grading in the normal manner as back-up protection for a down stream circuit, e.g. due to failure of the circuit breaker to clear a fault.

The combination of blocked lowset or Highset function and IDMTL back-up ensures fast operation for a circuit fault and, provided the IDMTL grading has been correctly calculated and set, will also provide back-up protection.

Busbar Zone Protection

On a radial substation with a defined incomer a simple logic busbar protection can be applied if each circuit is equipped with an Argus relay, Figure 3.4-2. As above, the Instantaneous Lowset or Highset elements in all relays can be set to the same setting, with the Incomers having 50ms grading delays set. For a fault on any feeder the instantaneous starter contact sends a blocking signal to inhibit operation of the high-speed protection on the incomer (see Figure 3.4-2). This inexpensive logic type protection has been widely applied and has an excellent operating record. However, if any of the outgoing circuits can feed power back on to the busbars, as can happen in an interconnected network, then simple non-directional busbar blocking protection cannot be applied.

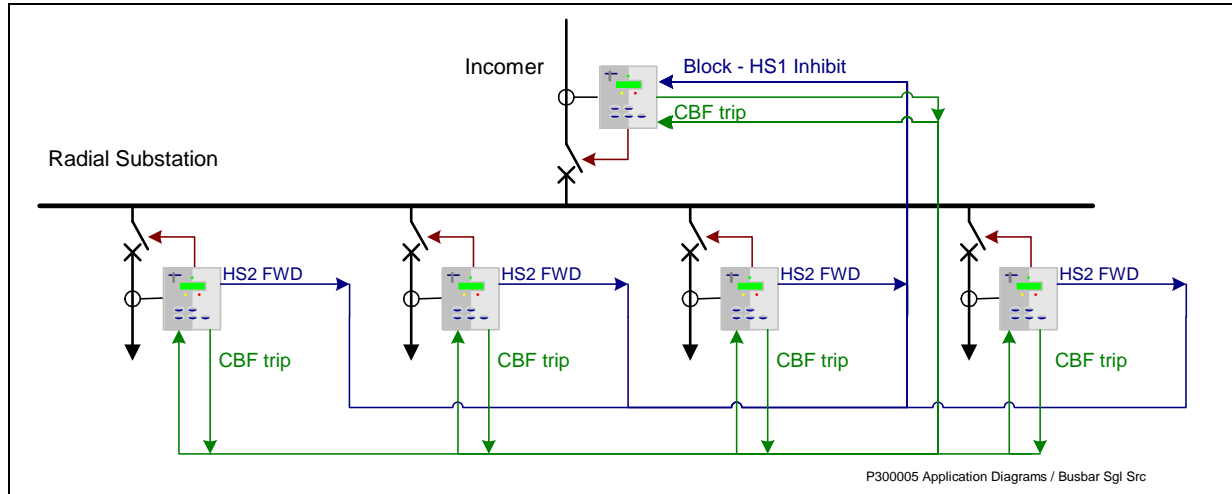

Figure 3.4-2 Busbar Zone Protection with Circuit Breaker Fail using Non-directional Relays. For use on Single-source Feed Networks

Where a Busbar fault can be back fed via a feeder then directional Argus relays can be installed on each circuit and employed as shown in Figure 3.4-3.

Phase and Earth Fault HighSet 1 elements (HS1) are applied to perform the busbar fault trip function and in all relays, both Feeder and Incomer, are set to the same current setting, above the maximum load current but beneath the minimum fault current, and with a minimum, typically 100ms, grading delay. Each HSI output is mapped to trip its associated Circuit Breaker, therefore, if no block signal is raised then all circuits with current above HS1 setting will be tripped.

Phase and Earth Fault HighSet 2 Forward elements (HS2) in all relays, both Feeder and Incomer, are set to the same setting and Forward with no delay (instantaneous) and are connected to the block (Inhibit) control line of the HS1 elements on all relays. Thus for faults outside the zone busbar protection all HS1 instantaneous elements will be inhibited. The forward IDMTL function is set to trip a faulted feeder in accordance with the system grading requirement.

With Argus relays a busbar fault trip initiation needs to be delayed by only 50ms, this is sufficient to enable a feeder circuit relay fast start output contact to block the incomer circuit relay should the fault be on a feeder.

Adoption of this philosophy will result in fast clearances of busbar faults coupled with through fault stability.

If Circuit Breaker fail is required then this must be mapped out from each relay into all other relays on the busbar, each relay must accept an external Trip input energised from any other relay; or the CBF outputs must be connected in parallel to a separate common Trip circuit for all Circuit Breakers.

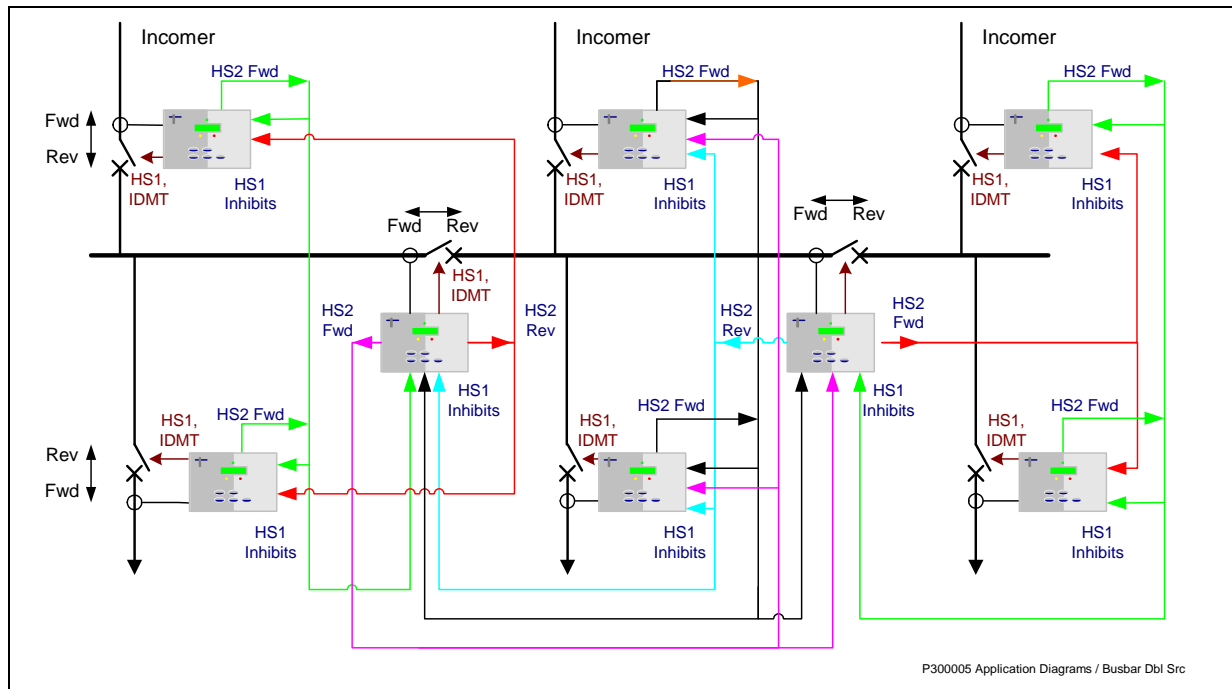

Figure 3.4-3 Busbar Zone Protection with Circuit Breaker Fail Employing Bi-Directional relays. For use on fully Interconnected Networks with Remote Supply Sources

If bus coupler and bus section circuit breakers are equipped with CTs and suitable VTs are available, then bi-directional Argus relays can be fitted to those circuits. Suitable steering of blocking and tripping signals can ensure that in the event of a busbar fault only the minimum plant is disconnected from the system. Figure 3.4-3 shows a typical example of this. If there are no CTs on the bus sections/couplers, a staged tripping logic can still be established to achieve the same result, although in a little longer time.

3.5 High Impedance Restricted Earth-fault Protection

The SEF/REF element of the Argus can be used to provide high impedance balanced or restricted earth-fault protection as shown in Figure 3.5-1. The SEF/REF starter output is used to provide an instantaneous trip output from the relay.

A separate Siemens Protection Devices Limited. Publication is available covering the calculation procedure for REF protection.

To summarise the calculation:

The relay Stability (operating) V_s voltage is calculated using worst case lead burden to avoid relay operation for through-fault conditions where one of the CTs may be fully saturated. The required fault setting (primary operate current) of the protection is chosen; typically, this is between 10 % and 25 % of the protected winding rated current. The relay setting current is calculated based on the secondary value of the operate current, note, however, that the summated CT magnetising current @ V_s must be subtracted to obtain the required relay operate current setting.

Since the relay operate current setting and stability/operating voltage are now known, a value for the series resistance can now be calculated.

A check is made as to whether a Non-Linear Resistor is required to limit scheme voltage during internal fault conditions – typically where the calculated voltage is in excess of 2kV.

The required thermal ratings for external circuit components are calculated.

Figure 3.5-2 shows the secondary wiring circuit, including the non-linear resistor, if required.

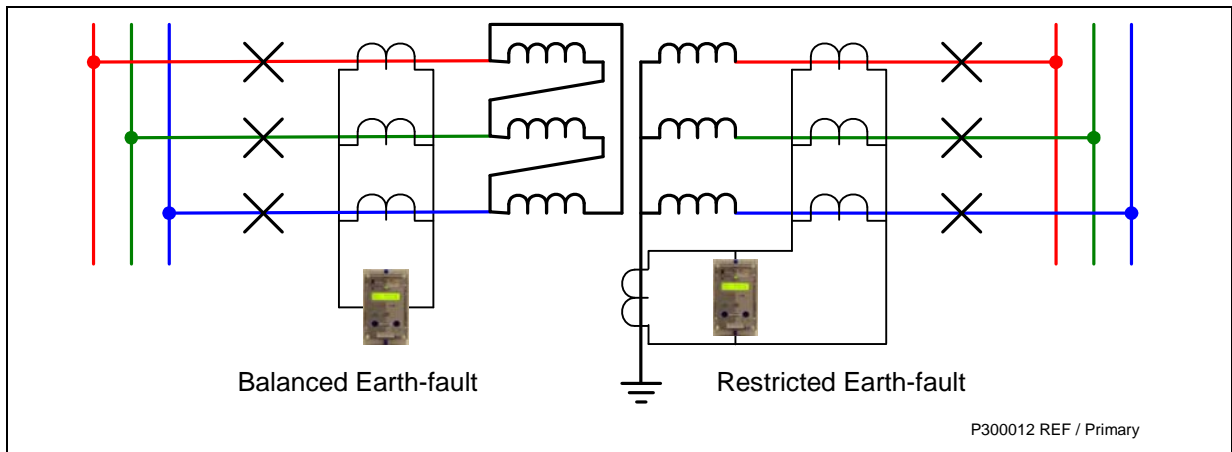

Figure 3.5-1 Balanced and Restricted Earth-fault protection of Transformers

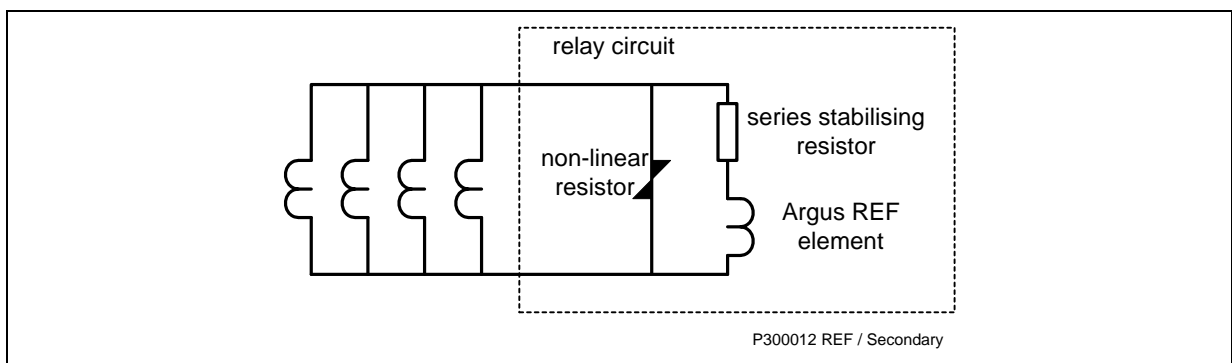

Figure 3.5-2 Restricted Earth-fault Secondary Circuit

Composite overcurrent and REF protection can be provided using a multi-element relay as Figure 3.5-3.

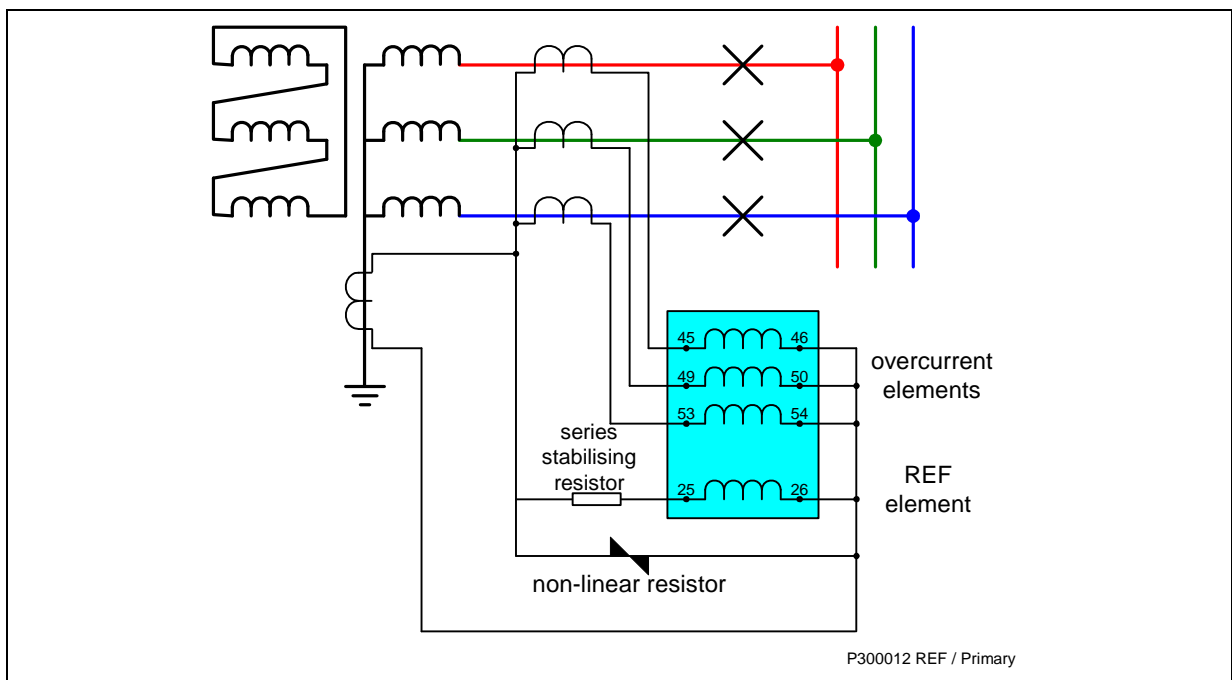

Figure 3.5-3 Composite Overcurrent and Restricted Earth-fault Protection

3.6 Circuit Breaker Fail Protection

The Argus relay incorporates a two-stage circuit breaker fail feature. If a designated trip relay operates and the circuit breaker fails to open, the protection algorithm continues to run for as long as current, above the starter level or CBF level detector setting, continues to flow and a continuous trip output is given. This combination of conditions is programmed to start a definite time lag feature designated "CB Fail 1". This function can be programmed to energise an output relay when the C.B. fail time delay is completed. At the same time operation of this timer starts a second time lag feature designated "CB Fail 2" and if the trip outputs already initiated do not stop the current flow through the relay, another relay can be programmed through the output matrix to trip a further breaker e.g. a bus section circuit breaker.

Schemes

These timers support schemes as follows:

- Single stage CB fail, where all adjacent upstream infeeds are tripped after DTL1 on detection of a CB fail occurrence.
- Two stage CB fail, where stage 1 DTL outputs attempt to re-trip the faulted CB in stage 1 time delay and when this fails the stage 2 time delayed output trips the relevant adjacent infeeds.

The circuit breaker fail feature can also be used to implement a multi-stage tripping scheme. A typical example of this is illustrated in Figure 3.4-2.

Setting Calculation

The time delay setting applied to the CB fail protection must be in excess of:

the longest CB operate time + relay reset time + a safety margin

Typically, 80 ms + 42 ms + 50 ms = 175ms (approximately)

3.7 Auto-reclose Applications

Argus 4 and Argus 6 only.

Automatic circuit reclosing is extensively applied to overhead line circuits where a high percentage of faults that occur are of a transient nature and cause no permanent damage to connected plant. The benefits of auto-reclosing are:

- Reduce to a minimum the loss of supply to the customer.
- Allows greater automation of the network with relevant cost savings.
- Instantaneous fault clearance is possible thereby minimising fault damage.

3.7.1 Reclose Time Setting

The reclose time is defined as the time between the auto-reclose scheme being energised and the operation of the output contacts that energise the circuit breaker closing circuit. Selection of the optimum time setting is influenced by the recloser characteristics, the type of load supplied, and the nature of the fault.

The recloser mechanism reset time and closing time (interval between energisation of the mechanism and the making of the contacts) or the recloser duty cycle make up the minimum reclose time imposed by the recloser.

Where the connected plant consists of a motor circuit, the motor type must be taken into consideration as regards the requirements of the auto-reclose scheme. Synchronous machines require a reclose time sufficiently long enough to ensure operation of their undervoltage protection, i.e. should not be reconnected. Whilst for induction motors the interruption period needs to be short to enable them to coast until reconnection of the supply.

For overhead lines applications the reclose time must be long enough to allow the ionised air to disperse. Factors that affect the de-ionisation time are the system voltage, cause of the fault, and weather conditions.

3.7.2 Reclaim Time Setting

The reclaim time is defined as the time window following a successful closing operation within which if a fault occurs the current reclose sequence will continue. After the Reclaim time if a fault occurs a new sequence will start. Under repetitive fault conditions a long reclaim time in excess of the interval between successive faults may cause unnecessary lockout and interruption of supply.

3.7.3 Shots to Lockout Setting

There are no strict guidelines for setting this parameter but a few factors need to be taken into consideration. The recloser design should be taken into account and the system conditions should be examined as to the nature of typical faults. If there is a sufficient percentage of semi-permanent faults which could be burnt away, e.g. fallen branches, a multi shot scheme would be appropriate. Alternatively, if there is a likelihood of permanent faults, a single shot scheme would provide a higher quality of supply.

3.7.4 Sequence Auto-reclosing

In Argus 4 & 6 auto-reclose Relays, the low-set overcurrent stage functions as the Instantaneous trip.

Complex sequences may be user programmed to give the best fault clearance strategy.

The Argus 4 and 6 relays provide auto-reclosing with sequence co-ordination of the Instantaneous low-set characteristics and Shot Counters. The source low-set is time delayed (i.e. time delayed instantaneous and grading and Sequence Co-ordination with a downstream instantaneous recloser is ensured. Typically, an auto-reclose sequence set to 2 Instantaneous Trips plus one Delayed Trip will restore supplies for 90% of fault conditions.

3.8 Trip Circuit Supervision

The Argus relay can be used to supervise one or more trip circuits, via status inputs, with the associated circuit breaker open or closed. A low value of d.c. current is passed through the entire trip circuit to monitor the auxiliary supply, the trip coil, its auxiliary switch, the C.B. secondary isolating contacts and the relevant wiring/links. If the circuit develops a fault and monitoring current flow ceases, the normally energised status input drops off and if it is user programmed to operate one of the output relays, then this relay gives a contact output to signal *Trip Circuit Fail*. In addition, the LCD display on the Argus relay will indicate "Trip Circuit FAIL".

To avoid giving spurious alarm messages while the circuit breaker is operating, the status input should be programmed to have a 400 ms drop-off delay.

Schemes, based on the Electricity Association H6/H5 schemes, are shown below.

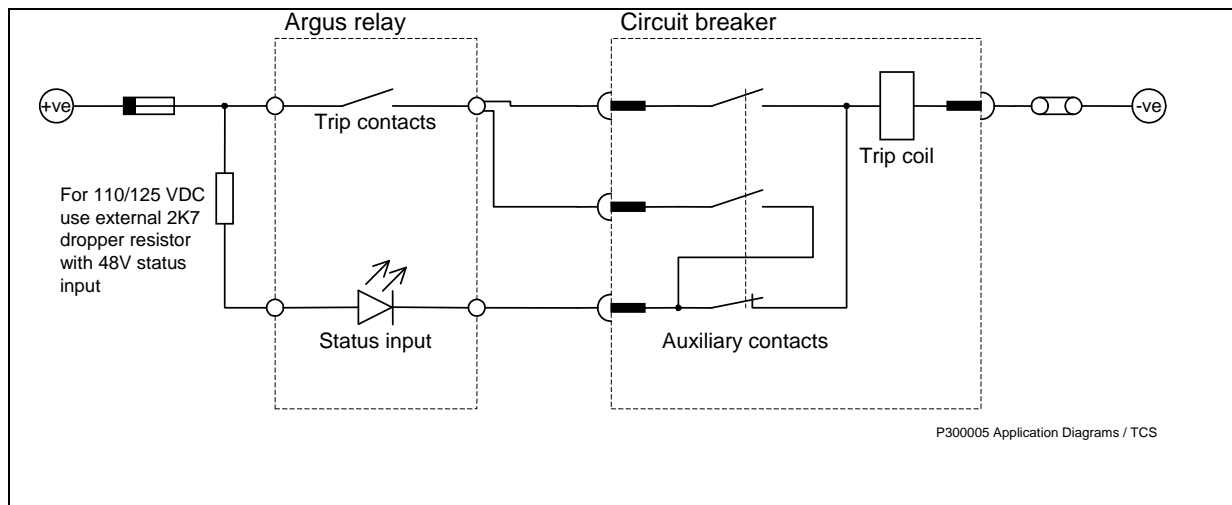

Figure 3.8-1 Engineering Recommendations S.15 H6 Trip Circuit Supervision scheme

This scheme provides continuous Trip Circuit Supervision of trip coil with circuit breaker Open or Closed. It does not, however, provide pre-closing supervision of the connections and links between the tripping contacts and the circuit breaker.

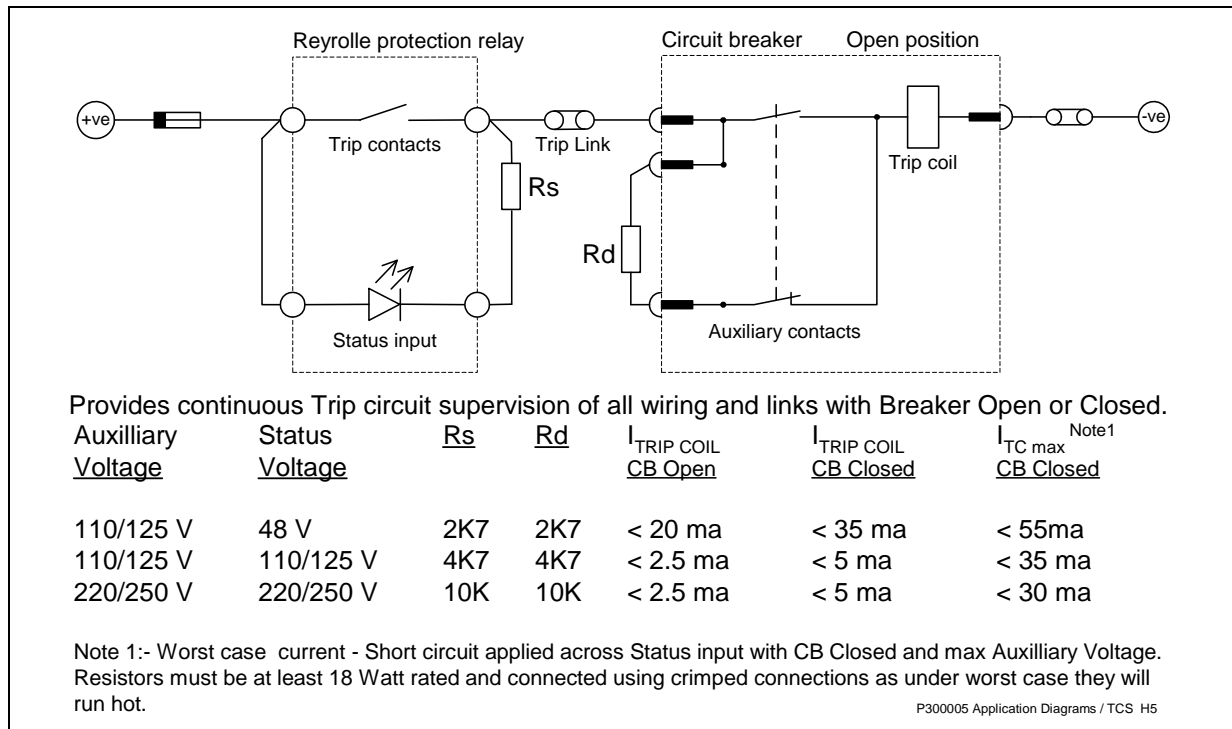

Figure 3.8-2 Engineering Recommendations S.15 H5 Trip Circuit Supervision scheme

This scheme provides continuous, high security, Trip Circuit Supervision of all wiring and links with circuit breaker Open or Closed. Note a TCS Alarm will be generated if the trip contact is latched.

3.9 Output Relays

The output relays in the Argus range can be programmed to be self or hand reset. In the hand reset mode, a status input can be programmed to electrically reset the hand reset output relays. In Figure 3.2-1, if the transformers at A and B are, for example, 132 / 33kV or 132 / 11kV and, on the 132kV side there are no local circuit breakers but motor operated isolators, then the reverse characteristic elements can be programmed to operate a hand reset output relay. This relay can be wired to give an intertrip signal and initiate isolator operation. In due course, this output relay can be remotely reset by a status input.

3.10 Post-fault Analysis

Argus overcurrent protection relays provide extensive information for post-fault analysis; however, to use this effectively the Argus must be correctly set when put into service. This section describes measures that should be taken to ensure the correct data is captured in the event of a fault.

3.10.1 Events, Fault and Waveform Records

Fault records provide textual information on the source of the trip within the Argus, i.e. the element that tripped and any elements that were picked up at the time of trip. This gives the first indication of the type of fault.

However, the fault record should be examined in coordination with the event records to see the full sequence of events leading to a trip. It is possible to identify developing and flashing faults using the event records.

If a waveform record is available, the current waveforms (and voltage waveforms in some models) allow the type of fault to be easily identified. However, the waveform record lasts only 1 second, whereas the event records will cover many seconds or minutes. If a fault is of a flashing nature this will be apparent from the event records, while the waveform record may show only the final overcurrent leading to trip.

3.10.2 Fault triggers

In order to generate a fault record it is important that the fault trigger is correctly set. A fault will be recorded if any element trips and it is mapped to an output relay that is defined as a fault trigger relay. Therefore, any output relay that trips a circuit breaker should be set as a fault trigger relay using the *Data Storage:Fault Trigger* setting. In addition, if it is required to record a fault for any other element, an output relay driven by that element should also be defined as a fault trigger relay.

3.10.3 Waveform triggers

In order to generate a waveform record on occurrence of a fault it is important that the waveform trigger is correctly set. Each type of fault (phase-fault, earth-fault or SEF) for which it is required to record a waveform must be set using the *Data.Storage:Waveform Trig* setting. This setting also allows waveform triggering to be enabled from external sources using the status inputs. If external waveform triggering is required the status input must also be correctly set using the *Status.Config:Waveform Trig* setting.

When the source of waveform triggers has been selected consideration should be given to the pre-trigger recording. Each waveform is 1 second long, therefore, for a delayed element, the current could be present for a few hundred milliseconds (or over 1 second) before a trip occurs. Following the trip output it is likely that the current will continue to be present for one to two hundred milliseconds before the circuit breaker interrupts the current.

The *Data.Storage:Waveform Pre-Trigger* setting allows a percentage, typically 80%, of the 1 second to be allocated to pre-trigger recording. The user should consider the application, the likely fault type, and the area of greater interest (inception of fault or post-trip waveform) when applying this setting,

3.10.4 ReyDisp (IEC 60870-5-103)

The Reydisp Evolution software allows the recorded data (events, fault records, waveform records) to be uploaded from the Argus to a PC for analysis. When saving data it is important to save the applied settings at the time of trip, in order to correctly interpret the data.

Get All Data

The ReyDisp 'Get All Data' command allows all data to be easily uploaded from the Argus.

If this command is selected ReyDisp will ask the user to specify a directory name (which will be created if it does not exist) and will then upload all events, all 5 fault records, all 5 waveform records and all settings from all 8 settings groups.

This ensures that all necessary data is available for post-fault analysis.

Section 4: Communication Interface

4.1 Introduction

Argus relays can communicate with controlling systems using either IEC60870-5-103 or MODBUS communications protocols. The protocol is selectable in the relay settings menu.

4.1.1 Comms Protocol Setting

The relay protocol can be selected from a default setting of IEC60870-5-103 to Modbus RTU whichever is required. The *Communications Interface:Comms Protocol* setting should match that of any communicating device.

4.2 IEC 60870-5-103

Argus relays can communicate with control and automation systems, or with PCs running ReyDisp software, to provide operational information, post-fault analysis and settings interrogation and editing. This section describes how to use the IEC 60870-5-103 compliant Informative Communication Interface with a control system or interrogating computer. Appropriate software within the control system or on the interrogating computer (e.g. ReyDisp Evolution) is required to access the interface.

This section specifies connection details provided in the Argus relays. For further information regarding the interface reference should be made to the separate Informative Communications Interface manual (reference 434/TM/5), which covers all Reyrolle products. See website www.siemens.com/energy

The same communications interface is used to provide control system connections and for dialogue communications by the protection engineer. An appropriate IEC 60870-5-103 control system interface will be required for the former application, while the latter is provided by ReyDisp Evolution software.

4.2.1 Physical Connection

The Argus complies with the physical requirements of IEC 60870-5-103 using fibre-optics however it is possible to apply more flexible, but non-compliant, settings for connection to PCs etc.

4.2.2 Medium

The communicating medium is optical fibre. The device communicating with the Argus should have a fibre-optic interface, preferably optimised for 62.5/125 µm glass fibre. If the communicating device, e.g. a PC, has an RS232C electrical interface, a fibre-optic to RS232 converter is required.

4.2.2.1 Sigma Fibre-optic to RS232 Converters

Siemens Protection Devices Limited. can provide a range of fibre-optic to RS232 converter devices:

- Sigma 1 – a panel mounting fibre-optic star coupler, for up to 29 slaves. An RS232 port is available at the front of the device. By default, communication is to the master fibre connections on the rear, however communication is automatically switched to the front RS232 port when a communicating programme is activated on it. Each fibre-optic port can be individually selected between 'Light On' and 'Light Off' (see section 0).
- Sigma 3 – a panel mounting fibre-optic to RS232 converter. Two RS232 ports are available, one at the rear for connection to a modem, and one at the front for connection to a local PC. By default the rear port is active, however, communication is automatically switched to the front port when a communicating programme is activated on it. The fibre-optic port can be selected between 'Light On' and 'Light Off' (see section 0).
- Sigma 4 – a loose fibre-optic to RS232 converter.

Full details of the above devices can be found by referring to the website www.siemens.com/energy

4.2.3 Recommended cable

Selection of fibre-optic cable is important. Fibres must be terminated with STTM (BFOC/2.5) connectors.

The recommended type is 62.5/125µm glass fibre. Communication distances over 1 km are achievable using this type of fibre.

4.2.4 Network Topology

Communication networks can be connected either in star or ring format.

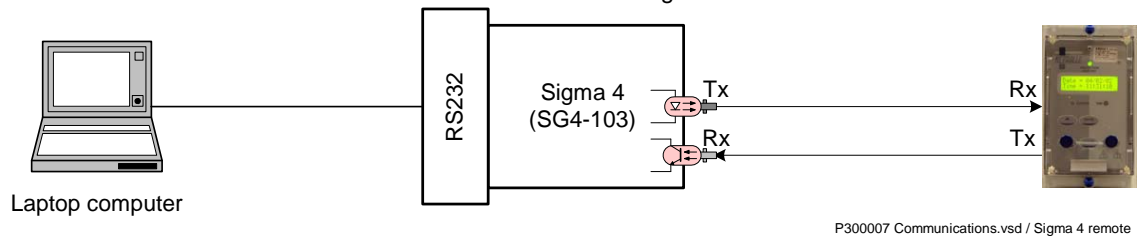

4.2.5 Figure 4.2-1 Settings

Communication parameters of *Communications Interface:Comms Baud Rate*, *Communications Interface:Comms Parity* and *Communications Interface:Line Idle* should match those of the communicating device.

4.2.6 IEC Class II Measurands

Class II measurands can be sent as either ASDU 3 (reports 1 current channel) or ASDU 9 (reports 9 channels, Ia, Ib, Ic, Va, Vb, Vc, P, Q). The values are returned as a fraction of a nominal value ie 1A, 63.5v. The *Communications Interface:IEC Class II Measurand* setting should be set as appropriate for each system.

4.2.7 IEC Class II Update period

The class II measurand is updated in the relay at a period dependant on the *Communications Interface:Class 2 Update Period* setting. This ranges from instantaneous (constantly updated) to every 60s (updated every minute).

4.2.8 IEC Class II scaling

The measurands returned are fractions of nominal system quantities. The maximum range of the measurand can be set either 1.2 or 2.4 times the nominal. Values that exceed this range will be returned as the maximum value and flagged overflow. Note using 2.4 times scaling will double the range but half the resolution per bit. The *Communications Interface:IEC Class II Scaling* setting should be set as appropriate for each system.

4.2.9 Baud Rate

Rates of 19200, 9600, 4800, 2400, 1200, 600, 300, 150, 110 and 75 bits per second are provided. However, only 19200 and 9600 are defined in IEC 60870-5-103, the additional rates are provided for local or modem communications.

The *Communications Interface:Comms Baud Rate* setting should match that of the communicating device, e.g. P.C.

4.2.10 Comms Parity

IEC 60870-5-103 defines transmission as using Even parity, however, in some instances an alternative may be required. The *Communications Interface:Comms Parity* setting allows parity of None to be selected. This setting should match that of the communicating device, e.g. PC.

4.2.11 Relay Address

Each relay on a network must have a unique address, between 1 and 254, as set by the *Communications Interface:Relay Address* setting. A relay with the default address of 0 will not be able to communicate.

4.2.12 Line Idle

The IEC60870-5-103 protocol defines a line idle state of Light On. Binary '0' is represented by light on, binary '1' is represented by light off, and when a device is not communicating it idles with the light on (sending '0'). This allows detection of a broken fibre condition. When the line is idling, a binary '0' should be received constantly. If binary '1' is received constantly, then no light is being received, hence the fibre may be broken.

The *Communications Interface:Line Idle* setting must be set to be either on or off to be compatible with the communicating device connected to the relay.

4.2.13 Data Echo

Argus relays may be connected in a ring, e.g. as shown in Fig.4.3. The optical ring architecture requires data to be passed from one relay to the next, therefore, when using this method, all relays in the ring must have the *Communications Interface:Data Echo* setting to On.

For Argus with individual connections (e.g. Figure 1.5-1 **Error! Reference source not found.**), or connected in a star topology (e.g. Figure 4), the setting should be set to Off.

Table 4-1 Communications Settings

Sub-menu: **Communications Interface**

| Setting name | Range (bold = default) | Units | Notes |
|------------------------------|--|-------|-------|
| Comms Protocol | IEC 60870-5-103 , MODBUS-RTU | | |
| IEC Class 2 Measurand | ASDU 3 , ASDU 9 | | |
| Class 2 Update Period | INST , 1, 2 .. 60 | Sec | |
| IEC Class 2 Scaling | 1.2x , 2.4x | | |
| Comms Baud Rate | 75, 110, 150, 300, 600, 1200, 2400, 4800, 9600, 19200 | baud | |
| Comms Parity | NONE, EVEN | | |
| Relay Address | 0 , 1...254 | | |
| Line Idle | LIGHT ON, LIGHT OFF | | |
| Data Echo | OFF , ON | | |

4.2.14 Modems

The communications interface has been designed to allow data transfer via modems. However, IEC 60870-5-103 defines the data transfer protocol as an 11 bit format of 1 start, 1 stop, 8 data and even parity, which is a mode most commercial modems do not support. High performance modems will support this mode.

4.2.15 Connecting a Modem to the Relay(s)

RS232C defines devices as being either Data Terminal Equipment (DTE) e.g. computers, or data Communications Equipment (DCE), e.g. modems, where one is designed to be connected to the other. In this case, two DCE devices (the modem and the fibre-optic converter) are being connected together, so a null terminal connector is required, which switches various control lines. The fibre-optic converter is then connected to the relay network Tx to Relay Rx and Rx to Relay Tx.

4.2.16 Setting the Remote Modem

The exact settings of the modem are dependent on the type of modem. Although most modems support the basic Hayes 'AT' command format, different manufacturers use different commands for the same functions. In addition, some modems use DIP switches to set parameters, others are entirely software configured.

Before applying the following settings, the modem's factory default settings should be applied, to ensure it is in a known state.

Several factors must be considered to allow remote dialling to the relays. The first is that the modem at the remote end must be configured as auto answer. This will allow it to initiate communications with the relays. Next, the user should set the data configuration at the local port, i.e. baud rate and parity, so that communication will be at the same rate and format as that set on the relay and the error correction is disabled.

Auto-answer usually requires two parameters to be set. The auto-answer setting should be switched on and the number of rings after which it will answer selected. The Data Terminal Ready (DTR) settings should be forced on. This tells the modem that the device connected to it is ready to receive data.

The parameters of the modem's RS232C port are set to match those set on the relay, set baud rate and parity to be the same as the settings on the relay and number of data bits to be 8 and stop bits 1. Note, although the Argus may be able to communicate with the modem at say 19200 bps, the modem may only be able to transmit over the telephone lines at 14400 bps. Therefore, a baud rate setting on which the modem can transmit should be chosen. In this example, a baud rate of 9600 should be chosen.

As the modems are required to be transparent, simply passing on the data sent from the controller to the device and vice versa, error correction and buffering should be turned off.

If possible Data Carrier Detect (DCD) should be forced on, as this control line will be used by the Fibre-optic converter.

Finally, these settings should be stored in the modem's memory for power on defaults.

4.2.17 Connecting to the Remote Modem

Once the remote modem has been configured correctly it should be possible to dial up the modem and make connection to the relay. As the settings on the remote modem are fixed the local modem should negotiate with it on connection choosing suitable matching settings. If it cannot do this, the local modem should be set with settings equivalent to those of the remote modem as described above.

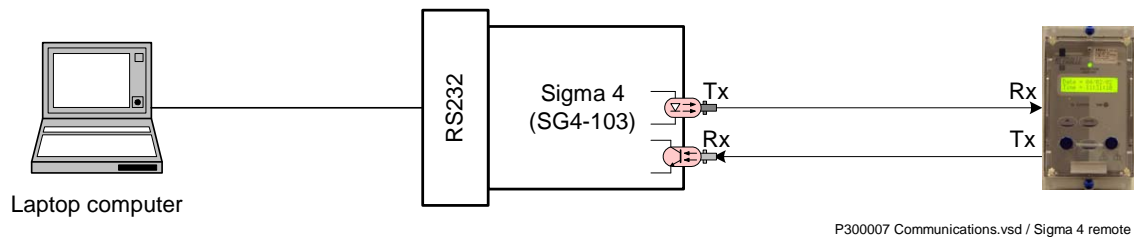

Figure 4.2-1 Communication to Argus Relay using Sigma 4 (Local Connection)

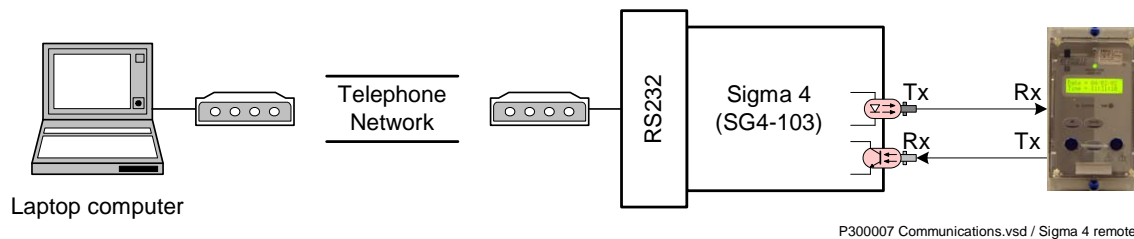

Figure 4.2-2 Communication to Argus Relay using Sigma 4 and Modem

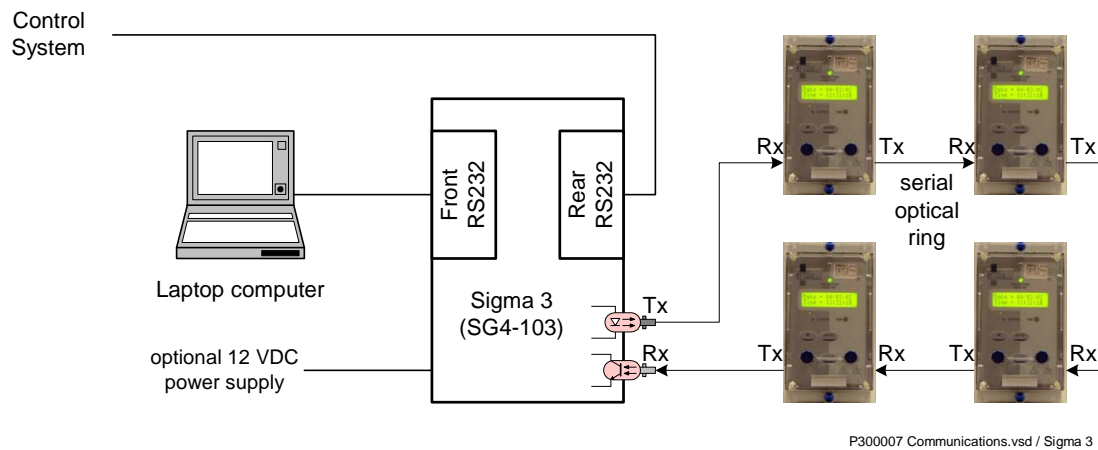

Figure 4.2-3 Communication to Multiple Argus Relays from Control System and Laptop with Sigma 3 and Fibre-optic Ring Network

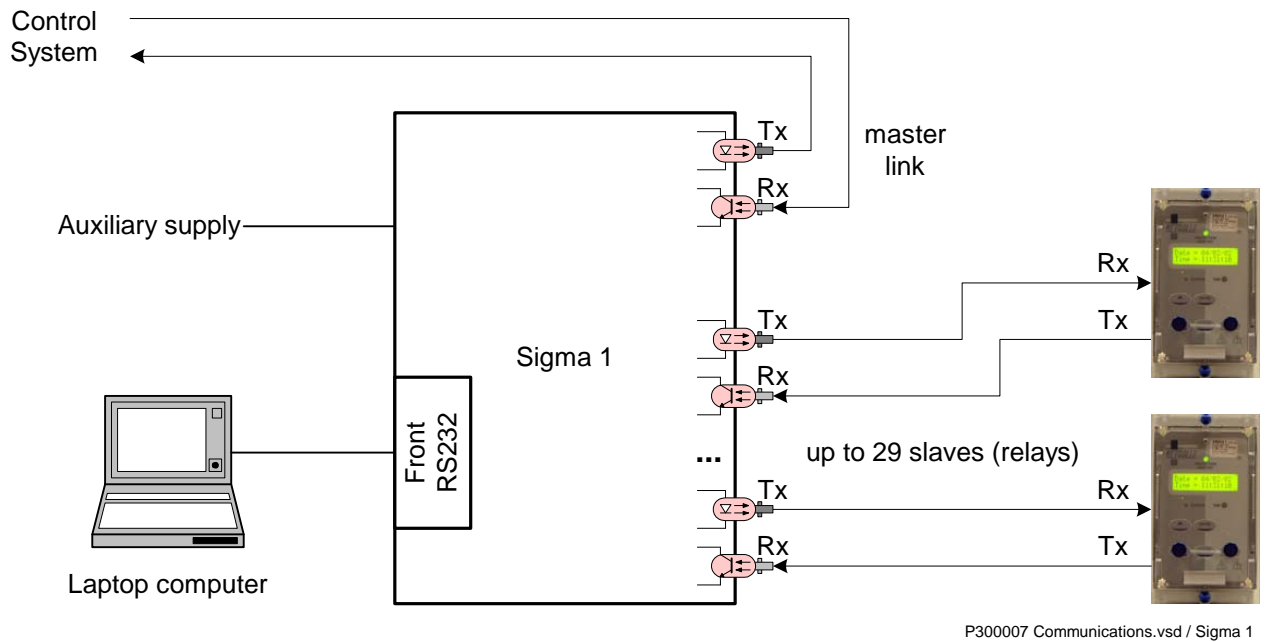

Figure 4.2-4 Communication to Multiple Argus Relays from Control System and Laptop with Sigma 1 and Fibre-optic Star Network

4.3 Introduction – Modbus RTU

This section describes how to use the Modbus Interface with a compliant control system. For further information regarding the interface, reference should be made to the Argus Modbus implementation report 434/TIR/14 available on website www.siemens.com/energy

The same communications interface is used to provide control system connections.

The Argus complies with the physical requirements of Modbus using fibre-optics or an RS485 interface.

4.3.1 Medium

The communicating medium is optical fibre or electrical RS485. The device communicating with the Argus should have an interface optimised for 62.5/125 μm glass fibre-optics, or RS485 electrical connection.

4.3.1.1 Sigma Fibre-optic to RS232 Converters

See previous section 4.2.2.1.

4.3.2 Recommended cable

Selection of fibre-optic cable is important. Fibres must be terminated with STTM (BFOC/2.5) connectors. The recommended type is 62.5/125 μm glass fibre. Communication distances over 1 km are achievable using this type of fibre.

The RS485 electrical interface can be connected using 120 ohm screened twisted pair wire i.e. Belden 9841 or equivalent.

4.3.3 Network Topology

Fibre optical communication networks can be connected singularly or in a star configuration. Modbus does not support a fibre optic ring configuration.

RS485 electrical connection can be used in a single or multi-drop configuration. The last device must be terminated correctly.

Figure 4.2-1 & Figure 4.2-4 illustrate typical network arrangements.

4.3.4 Settings

Communication parameters of *Communications Interface:Comms Baud Rate*, *Communications Interface:Comms Parity* and *Communications Interface:Line Idle* should match those of the communicating device.

4.3.5 Comms Protocol

See previous section 4.1.1

4.3.6 Baud Rate

Rates of 19200, 9600, 4800, 2400, 1200, 600, 300, 150, 110 and 75 bits per second are provided.

The *Communications Interface:Comms Baud Rate* setting should match that of the communicating device,

4.3.7 Comms Parity

The *Communications Interface:Comms Parity* setting allows parity of Even or None to be selected. This setting should match that of the communicating device.

4.3.8 Relay Address

Each relay on a network must have a unique address, between 1 and 247, as set by the *Communications Interface:Relay Address* setting. A relay with the default address of 0 will not be able to communicate. The actual number of devices will be limited to 32 devices on any one RS485 connection.

4.3.9 Line Idle

If the communication medium is fibre-optic the *Communications Interface:Line Idle* setting defines the quiescent state. When set as Light On binary '0' is represented by light on, binary '1' is represented by light off and vice versa for Light Off mode. While in Light On mode and the device is not communicating it maintains the Light On mode to allow breaks in the cable to be detected. These potential breaks would not be detected when the device mode is set to Light Off.

This must be set to OFF when connected to the RS485 electrical connection.

4.3.10 Data Echo

All relays must have the *Communications Interface:Data Echo* setting to OFF.

Table 4-2 Communications Settings

Sub-menu: **Communications Interface**

| Setting name | Range (bold = default) | Units | Notes |
|------------------------|--|-------|-------|
| Comms Protocol | IEC 60870-5-103 , MODBUS-RTU | | |
| Comms Baud Rate | 75, 110, 150, 300, 600, 1200, 2400, 4800, 9600, 19200 | baud | |
| Comms Parity | NONE, EVEN | | |
| Relay Address | 0 , 1...254 | | |
| Line Idle | LIGHT ON, LIGHT OFF | | |
| Data Echo | OFF , ON | | |

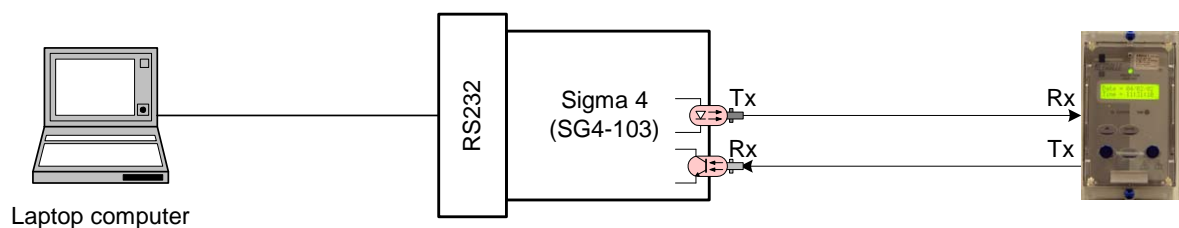

P300007 Communications.vsd / Sigma 4 remote

Figure 4.3-1 Communication to Argus Relay using Sigma 4 (Local Connection)

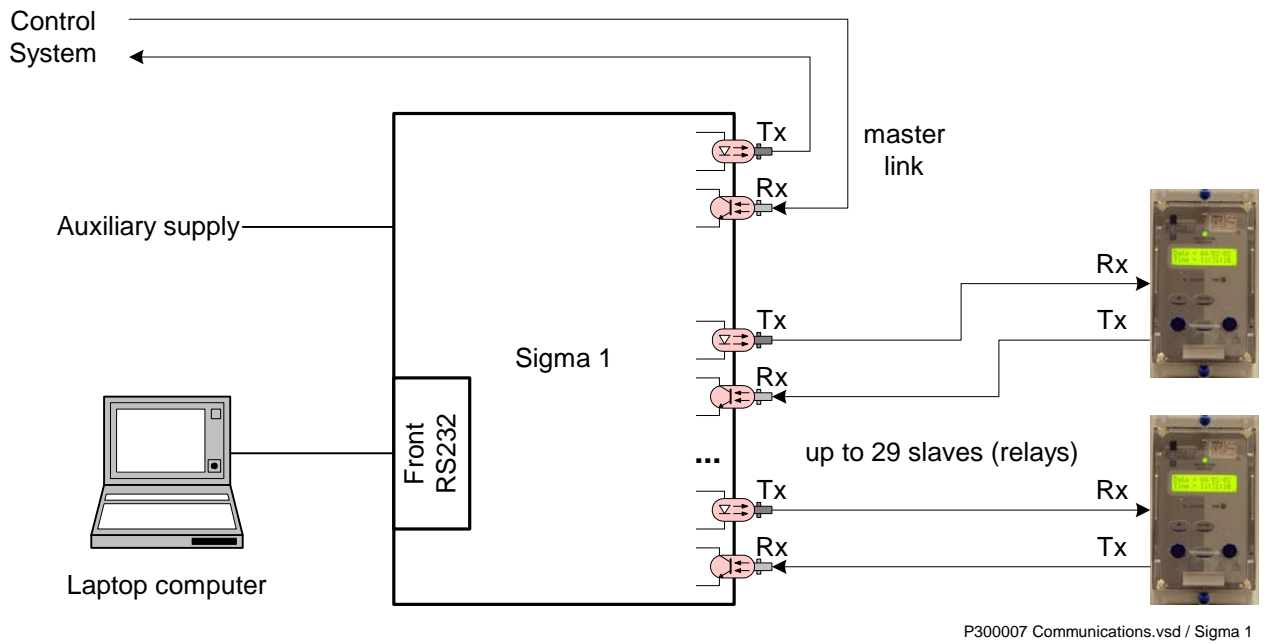

Figure 4.3-2 Communication to Multiple Argus Relays from Control System and Laptop with Sigma 1 and Fibre-optic Star Network

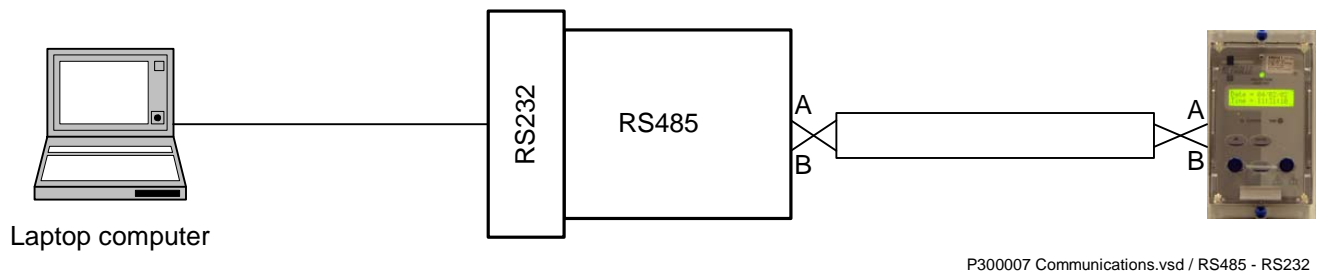

Figure 4.3-3 Communication to Argus Relay using RS485 – RS232 converter (Local Connection)

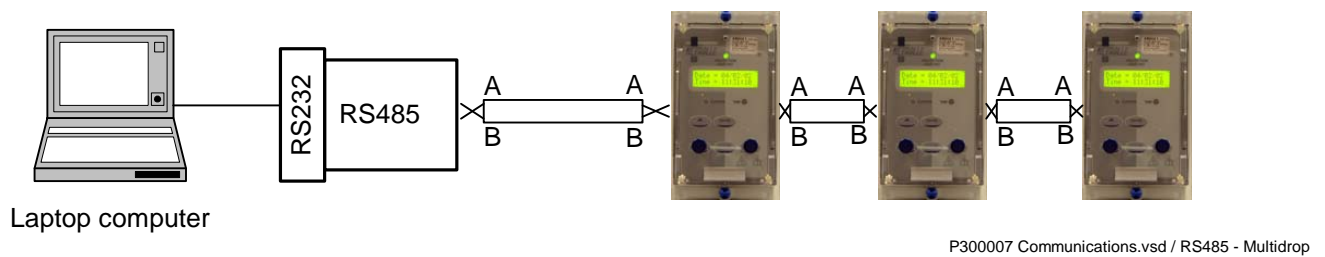

Figure 4.3-4 Communication to Argus Relay using RS485/RS232 converter (Multidrop Connection)

4.3.11 Glossary

Baud Rate

See bits per second.

Bit

The smallest measure of computer data.

Bits Per Second (BPS)

Measurement of data transmission speed.

Data Bits

A number of bits containing the data. Sent after the start bit.

Half-Duplex Asynchronous Communications

Communications in two directions, but only one at a time.

Hayes 'AT'

Modem command set developed by Hayes Microcomputer products, Inc.

Modem

MOdulator / DEModulator device for connecting computer equipment to a telephone line.

Parity

Method of error checking by counting the value of the bits in a sequence, and adding a parity bit to make the outcome, for example, even.

Parity Bit

Bit used for implementing parity checking. Sent after the data bits.

RS232C

Serial Communications Standard. Electronic Industries Association Recommended Standard Number 232, Revision C.

Start Bit

Bit (logical 0) sent to signify the start of a byte during data transmission.

Stop Bit

Bit (logical 1) sent to signify the end of a byte during data transmission.